

**CODE 2**

**OECD STANDARD CODE  
FOR THE OFFICIAL TESTING OF AGRICULTURAL  
AND FORESTRY TRACTOR PERFORMANCE**

## TABLE OF CONTENTS

1.	OFFICIAL APPROVAL.....	2-3
1.1	Agricultural and Forestry Tractors Eligible for Test.....	2-3
1.2	Tests Eligible for OECD Approval.....	2-3
2.	EXPLANATION OF TERMS USED IN PERFORMANCE TESTING:.....	2-4
2.1	Rated Speed.....	2-4
2.2	Engine Power.....	2-4
2.3	Belt Power.....	2-4
2.4	Power Take-Off Power.....	2-4
2.5	Power at the Drawbar.....	2-4
2.6	Maximum Drawbar Pull.....	2-5
2.7	Fuel Consumption.....	2-5
2.8	Definitions Relating to Dimensional Measurements and Checks.....	2-5
2.9	Slip.....	2-6
2.10	Unballasted Mass.....	2-7
2.11	Ballasted Mass.....	2-7
3.	REQUIREMENTS PRIOR TO TESTS:.....	2-7
3.1	Selection.....	2-7
3.2	Running-In and Preliminary Adjustments.....	2-7
3.3	Technical Specifications Sheet and Information Essential to the Test Station.....	2-8
3.4	General Rules and Directions for Tests.....	2-8
4.	PERFORMANCE TESTS.....	2-9
4.1	Power Take-Off and Engine Tests.....	2-9
4.2	Hydraulic Power.....	2-17
4.3	Hydraulic Lift.....	2-19
4.4	Drawbar Power and Fuel Consumption.....	2-20
4.5	Turning Area and Turning Circle.....	2-26
4.6	Centre of Gravity.....	2-27
4.7	Braking.....	2-27
4.8	External Noise Level.....	2-29
4.9	Waterproofing Test.....	2-30
5.	SPECIAL CASES.....	2-32
5.1	Special case of testing 2-WD and 4-WD versions of the same tractor.....	2-32
5.2	Re-testing.....	2-32
5.3	Minor modifications.....	2-33
5.4	Non-minor modifications open to validation by extension.....	2-33
	ANNEX A SPECIMEN TEST REPORT.....	2-34
1.	SPECIFICATIONS OF TRACTOR.....	2-34
2.	TEST CONDITIONS.....	2-44
3.	TEST RESULTS.....	2-46
4.	OPTIONAL TEST RESULTS.....	2-55
5.	REPAIRS.....	2-58
6.	REMARKS.....	2-58
7.	ANNEX (CURVES).....	2-58
8.	MINOR MODIFICATION CERTIFICATE.....	2-58

## CODE 2

### OECD STANDARD CODE FOR THE OFFICIAL TESTING OF TRACTOR PERFORMANCE

#### 1. OFFICIAL APPROVAL

Official approval will be granted by the OECD on the basis of the present Code.

##### *1.1 Agricultural and Forestry Tractors Eligible for Test.*

Self-propelled wheeled vehicles, having at least two axles, or with tracks, designed to carry out the following operations, primarily for agricultural and forestry purposes:

- to pull trailers;
- to carry, pull or propel agricultural and forestry tools or machinery and, where necessary, supply power to operate them with the tractor in motion or stationary.

##### *1.2 Tests Eligible for OECD Approval*

#### Compulsory Tests

Approval shall require checking as follows:

- Main power take-off<sup>1</sup> (section 4.1.1) and five extra points for calculating fuel consumption characteristics (section 4.1.3.1);
- Hydraulic power<sup>2</sup> (section 4.2.2) and lifting force (section 4.3);
- Drawbar power and fuel consumption (unballasted tractors) (section 4.4.2).

#### Optional Tests<sup>3</sup>

Approval of any optional tests shall require checking as follows:

- Engine test (section 4.1.2);
- Additional Power take-off ratio (economy) (section 4.1.3.2)
- Performance at the belt or the belt pulley shaft (section 4.1.5);

---

<sup>1</sup> Tractors without a main power take-off or with one that cannot transmit the full engine power can be tested at the engine flywheel or by drawbar tests as specified in 4.4.6. The testing station in agreement with the manufacturer shall make the choice between the two methods.

<sup>2</sup> Tractors without a lifting system and/or without a hydraulic service coupling remain eligible under the Code. However, the design of these tractors shall be specified in the test report.

<sup>3</sup> Optional tests may be performed and reported in any combination provided they are requested simultaneously with the compulsory tests

- Performance in a hot atmosphere (4.1.6);
- Low temperature starting test (4.1.7);
- Additional drawbar tests (section 4.4.3);
- Ten-hour test (ballasted tractors) (section 4.4.4);
- Axle power determination (section 4.4.7);
- Turning area and turning circle (section 4.5);
- Centre of gravity (section 4.6);
- Braking (wheeled tractors only) (section 4.7);
- External noise level (wheeled tractors only) (section 4.8);
- Waterproofing test (section 4.9).

### **Repeats of Any of the Compulsory or Optional Tests at Different Settings**

Approval shall require checking as follows:

- Eligibility for the same category;
- Compliance with test conditions under the Code;
- Clear specification of differences from original tests and caveat;
- Compliance with Specimen Test Report;
- Results.

### **Other Tests**

Tests performed according to other internationally recognized methods, to be reported and clearly marked as not being subject to the OECD approval procedure. Such test methods would have to be mentioned in the report and made available to the OECD in a published form, in either of the official languages of the Organisation.

## **2. EXPLANATION OF TERMS USED IN PERFORMANCE TESTING:**

### **2.1 *Rated Speed***

The engine speed specified by the manufacturer for continuous operation at full load.

### **2.2 *Engine Power***

The power measured at the flywheel or the crankshaft.

### **2.3 *Belt Power***

The power measured at the belt dynamometer.

### **2.4 *Power Take-Off Power***

The power measured at any shaft designed by the tractor manufacturer to be used as a power take-off.

### **2.5 *Power at the Drawbar***

The power available at the drawbar, sustainable over a distance of at least 20 metres.

## 2.6 *Maximum Drawbar Pull*

The mean maximum sustained pull, which the tractor can maintain at the drawbar over a given distance, the pull being exerted horizontally and in the vertical plane containing the longitudinal axis of the tractor.

## 2.7 *Fuel Consumption*

### 2.7.1 Units of Consumption

When consumption is measured by mass, to obtain hourly consumption by volume and the work performed per unit volume of fuel, a conversion of units of mass to units of volume shall be made using the fuel density value at 15°C.

When consumption is measured by volume, the mass of fuel per unit of work shall be calculated using the density corresponding to the fuel temperature at which the measurement was made. This figure shall then be used to obtain hourly consumption by volume and the work performed per unit volume of fuel, using the density value at 15°C for conversion from units of mass to units of volume.

### 2.7.2 Specific fuel consumption

The mass of fuel consumed per unit of work.

### 2.7.3 Specific energy

Work per unit volume of fuel consumed.

## 2.8 *Definitions Relating to Dimensional Measurements and Checks*

### 2.8.1 Track (wheel/track)

#### **Preliminary definition: median plane of the wheel**

The median plane of the wheel is equidistant from the two planes containing the periphery of the rims at their outer edges.

#### **Definition of track (wheel/track)**

The vertical plane through the wheel axis intersects its median plane along a straight line which meets the supporting surface at one point. If **A** and **B** are the two points thus defined for the wheels on the same axle of the tractor, then the track width is the distance between points **A** and **B**. The track may be thus defined for both front and rear wheels. Where there are twin wheels, the track is the distance between two planes each being the median plane of the pairs of wheels.

For track-laying tractors, the track is the distance between the median planes of the tracks.

#### **Additional definition: median plane of the tractor**

Take the extreme positions of points **A** and **B** for the tractor rear axle, which gives the maximum possible value for the track. The vertical plane at right angles to the line **AB** at its centre point is the median plane of the tractor.

### 2.8.2 Wheelbase

The distance between the vertical planes passing through the two lines **AB** as defined above, one for the front wheels and one for the rear wheels.

### 2.8.3 Tyre inflation pressure and Tyre radius Index

All dimensional specifications of the tractor refer to the dynamic radius index of the tested tractor as per ISO 4251-1:1998. Testing conditions refer to the pressure specified by the manufacturer of the tyres mounted on the tested tractor according to the load to be borne. These pressures will often give a different radius from the Tyre Radius Index.

### 2.8.4 Ground clearance

The distance between the supporting surface and the lowest point of the tractor.

### 2.8.5 Length

The distance between the two vertical planes at right angles to the median plane of the tractor and touching its front and rear extremities. All parts of the tractor and in particular the components projecting at the front or rear (e.g. drawbar) being fully contained between these two planes.

Removable hitch components at front and rear are not included in the length.

### 2.8.6 Width

The distance between two vertical planes parallel to the median plane of the tractor, each plane touching the outermost point of the vehicle on its respective side. All parts of the tractor, in particular all fixed components projecting laterally (i.e. wheel hubs), are contained between these two planes.

### 2.8.7 Height

The distance between the supporting surface and the horizontal plane touching the uppermost part of the vehicle.

## 2.9 Slip

2.9.1 Slip of the driving wheels or tracks is determined by the following formula:

$$\text{Wheel or track slip (\%)} = 100 (N_1 - N_0)/N_1$$

where  $N_1$  is the sum of the revolutions of all driving wheels or tracks for a given distance with slip, and  $N_0$  is the sum of the revolutions of all driving wheels or tracks for the same distance without slip.

In the case of tractors having four driving wheels not mechanically locked together, the number of revolutions of each wheel should be separately recorded and the slip calculated for each wheel. If the results differ by more than 5 per cent, they should be noted and separately reported.

2.9.2 Belt slip is determined by the following formula:

$$\text{Belt slip (\%)} = 100 (n_0 - n_1)/n_0$$

Where  $n_0$  and  $n_1$  are the number of revolutions per minute of the driven pulley without slip and under load respectively.

### **2.10 Unballasted Mass**

The mass of the tractor without ballasting devices; and in the case of tractors with pneumatic tyres, without liquid ballast in the tyres. The tractor shall be in running order with tanks, circuits and radiator full and any track equipment or additional front wheel drive components required for a normal use. The driver mass is not included.

### **2.11 Ballasted Mass**

The mass of the tractor with ballasting devices; and in the case of tractors with pneumatic tyres, sometimes with liquid ballast in the tyres. The tractor shall be in running order with tanks, circuits and radiator full and any track equipment or additional front wheel drive components required for a normal use. The driver mass is not included.

## **3. REQUIREMENTS PRIOR TO TESTS:**

### **3.1 Selection**

The tractor submitted for the test shall be taken from series production by the manufacturer, with the agreement of the testing station.

The tractor shall normally be a production model in all respects, strictly conforming to the description and specification sheet submitted by the manufacturer.

The testing of a pre-production model tractor is permitted exceptionally. If this is done, when the report is published, the testing station must certify in the report that it has checked that the series production conforms to the tested tractor.

The test report shall state how the tractor was selected.

### **3.2 Running-In and Preliminary Adjustments**

The tractor shall be new and run in by the manufacturer before the test in collaboration with the testing station, under the responsibility of the manufacturer and in accordance with his usual instructions. If this procedure is impracticable due to the tractor being an imported model, the testing station may itself run in the tractor provided that the authority of the manufacturer or his representative, who will remain responsible for the running-in, is obtained.

The adjustment of the carburettor or the injection pump and the setting of the governor shall conform to the specifications provided by the manufacturer.

The manufacturer may make adjustments in conformity with the specifications during the period prior to testing. These adjustments shall not be changed during the test.

The test report shall state the place and duration of running in.

### 3.3 *Technical Specifications Sheet and Information Essential to the Test Station*

The tractor manufacturer shall supply a specification of the tractor consisting of the items listed in the specimen test report, as well as any further data required to carry out the tests.

These technical specifications shall be checked as far as possible by the testing station. (The extent of checking shall be recorded in the test report as specified in the 'specimen test report', Annex A.)

#### 3.3.1 Guidance for manufacturers and test stations when checking dimensions:

The tractor must be standing on an impenetrable horizontal surface. Lengths and widths are measured on horizontal lines and heights on vertical lines;

The vehicle must be stationary with wheels or tracks and components as if it were travelling in a straight line, unless otherwise stated;

The dimensions shall apply to new vehicles normally equipped, tyre pressure being adjusted to give the dynamic radius index appropriate to the tyre size (see ISO 4251-1:1998).

### 3.4 *General Rules and Directions for Tests*

#### 3.4.1 Manufacturer's instructions

Once the test has started the tractor shall never be operated in a way that is not in accordance with the manufacturer's published instructions in the form of an operating handbook unless specifically required by test criteria and then only by arrangement with the manufacturer

#### 3.4.2 Permissible measurement tolerances

Rotational speed:	± 0.5 %
Time:	± 0.2 s
Distance:	± 0.5 %
Force:	± 1.0 %
Mass:	± 0.5 %
Atmospheric pressure:	± 0.2 kPa
Tyre pressure:	± 5.0 %
Hydraulic system pressure:	± 2.0 %
Temperature of fuel, etc.:	± 2.0°C
Wet and dry bulb thermometers:	± 0.5°C

These values shall be used unless otherwise specified by a test procedure.

#### 3.4.3 Auxiliary equipment

For all tests, accessories such as the hydraulic lift pump or air compressor may be disconnected only if it is practicable for the operator to do so as normal practice in work, in accordance with the handbook and without using tools, except as otherwise specified for a particular test. If not, accessories should remain connected and operate at minimum load.

The fan speed shall always be measured in the power take-off and the drawbar tests and recorded with each test point.

#### 3.4.4 Ambient conditions

No corrections shall be made to the test results for atmospheric conditions or other factors. Atmospheric pressure shall not be less than 96.6 kPa. If this is not possible because of conditions of altitude, a modified injection pump setting may have to be used, details of which will be included in the report. The pressure will be noted in the report. Stable operating conditions must have been attained at each load setting before beginning test measurements.

Temperature limits are given in the individual test procedures below.

#### 3.4.5 Fuels and lubricants

Fuels and lubricants shall be selected from the range of products commercially available in the country where the equipment is tested but shall conform to the minimum standards approved by the tractor manufacturer. If the fuel or lubricant conforms to a national or international standard, it shall be mentioned and the standard stated.

#### 3.4.6 Repairs during tests

All repairs made during the tests shall be noted in the test report, together with comments on any practical defects or shortcomings about which there is no doubt.

### 4. PERFORMANCE TESTS

#### 4.1 *Power Take-Off and Engine Tests*

If the manufacturer does not allow the use of the main power take off to transmit the full power, or the mode of operation or design prevents it, then the engine power can be tested at the flywheel. If neither of these tests can be achieved, a drawbar test must be carried out as described in 4.4.6.

Even if the alternative power test is performed, if there is a main power take-off fitted, it must be tested as described in 4.1.4

#### **Test requirements**

The torque and power values in the test report shall be obtained from the dynamometer bench without correction for losses in power transmission between the power take-off and the dynamometer bench.

In all tests, the shaft connecting the power take-off to the dynamometer shall not have any appreciable angularity.

The ambient temperature shall be  $23 \pm 7^{\circ}\text{C}$

If, in the test bench, use is made of an exhaust gas discharge device, it must not affect the engine performance.

The various tests shall be carried out continuously.

## Essential measurements

In addition to the performance measurements required in each test below, the following shall also be measured and recorded in the report:

- Fuel temperature at a suitable point between the tank and the engine;
- Oil temperature at a suitable point in the oil flow;
- Coolant temperature at the outlet of the cylinder block or cylinder head before the thermostat or, in the case of air-cooled engines, the engine temperature at a point specified by the manufacturer;
- Air temperature measured at two points: one approximately 2 m in front of the tractor and approximately 1.5 m above the ground, the other at the engine air intake;
- Atmospheric pressure;
- Relative humidity.

## Graphical presentation of results

The test report shall include presentation of the following curves made for the full range of engine speed available:

- Power as a function of speed (with standard power take-off speed indicated);
- Equivalent crankshaft torque as a function of speed (except for fluid transmission);
- Hourly and specific fuel consumption as a function of speed;
- Specific fuel consumption as a function of power.

Results from any tests listed under 4.1.1 or 4.1.3 below that have been carried out shall be displayed on the same chart (except for the fuel consumption isometric curves).

### 4.1.1 Main power take-off

(Able to transmit the full power of the engine)

#### 4.1.1.1 Maximum power test

The governor control being set for maximum power, the tractor shall operate for a period of one hour subsequent to a sufficiently long warming-up period for power to become stabilised.

The maximum power quoted in the test report shall be the average of no less than six readings made during the one-hour period, evenly spread over the period. If the power variation deviates by more than 2 per cent from the average, the test shall be repeated. If the variation continues, the deviation shall be stated in the report.

#### 4.1.1.2 Test at full load and varying speed

The hourly fuel consumption, torque and power are measured as a function of speed. To plot the curves, the test shall go down to an engine speed at least 15 per cent below the speed at which maximum torque occurs or to an engine speed at least 50 per cent of rated engine speed, whichever speed is lower. This is subject to any limitations such as safe operation of the tractor and test equipment or as stated by the manufacturer in agreement with the test station.

#### 4.1.1.3 Tests at varying load

The governor control is set for maximum power:

- at rated engine speed;
- at standard power take-off speed [540 or 1 000 min<sup>-1</sup>(rev/min)].

4.1.1.3.1 Torque, engine speed and hourly fuel consumption shall be recorded at the following loads:

4.1.1.3.1.1 The torque corresponding to maximum power available at rated engine speed and at standard power take-off speed;

4.1.1.3.1.2 85 per cent of the torque obtained in 4.1.1.3.1.1;

4.1.1.3.1.3 75 per cent of the torque defined in 4.1.1.3.1.2;

4.1.1.3.1.4 50 per cent of the torque defined in 4.1.1.3.1.2;

4.1.1.3.1.5 25 per cent of the torque defined in 4.1.1.3.1.2;

4.1.1.3.1.6 Unloaded (with the brake disconnected if the residual torque is greater than 5 per cent of the measured value in 4.1.1.3.1.2).

4.1.2 Engine tests (Engine performance tests in addition to, or in place of, the main power take-off tests)

##### 4.1.2.1 Additional test requirements for engine-only tests

Any accessory that is not necessary for the continuous operation of the engine, such as the hydraulic lift pump or air compressor shall be disconnected if this is possible.

The dynamo, or generator, with no load, shall remain connected and all other components necessary for the operation of the engine in the tractor shall remain in operation, such as air cleaner, exhaust muffler and fan.

The engine must be tested equipped with all the accessories, including the cowling, required for continuous operation of the tractor and shall be installed in the same relative position to them as when installed in the tractor.

The dynamometer bench shall be coupled directly to the crankshaft or to some other suitable power outlet which shall be stated in the test report.

##### 4.1.2.2 Test results

All the tests listed as tests at the main power take-off will be made except when the test is carried out in addition to a main power take off test, in which case the one-hour test can be omitted. The measurements normally made at the standard speed of the power take-off will not of course be made for tractors with no power take-off.

Sufficient data shall be obtained to relate specific fuel consumption, power, torque and engine speed throughout the working range of the engine. The results shall be presented graphically on one chart showing torque (ordinate) and speed (abscissa) curves of equal specific fuel consumption and equal power. The values of speed and torque may be shown respectively as percentage values of the rated speed and the torque at rated speed. The results shall also be presented in a table as shown in the specimen test report.

#### 4.1.3 Fuel consumption tests

##### 4.1.3.1 Five extra points for calculating fuel consumption characteristics

The power test at power take-off or engine serves not only to show the power available at the power take-off shaft, but also to establish fuel consumption figures and a diagram, which characterise the engine itself.

The specific fuel consumption figures measured at these 5 additional points, together with the full load- and the governor control curve- results, enable the evaluation of fuel economy for the tested tractor for all kinds of tractor power take-off operation. These figures also enable comparison of different tractors and a guide to fuel economy in drawbar work.

In each case they allow for the comparison of fuel economy within the whole range of possible operating points.

Typical operation for these 5 extra points could be described as follows, point (1) being that obtained at rated engine speed in the main test:

point (2)	high power at max. speed:	Heavy drawbar- work
point (3)	high power at 90% speed:	Heavy drawbar- or power take-off work at standard speed
point (4)	low power at 90% speed:	Light power take-off- or drawbar- work
point (5)	high power at 60% speed:	Heavy drawbar- or power take-off work at economy power take-off speeds or automatic engine speeds, near the most economical operating range of engine
point (6)	low power at 60% speed:	Light drawbar- or power take-off work at reduced speeds.

#### **Tests at varying load, point (1) and additional points (2) to (6) above.**

Torque, engine speed and hourly fuel consumption shall be recorded at the following loads:

4.1.3.1.1 maximum power at rated engine speed (4.1.3.1.1) [point (1)];

4.1.3.1.2 80 % of power obtained in 4.1.3.1.1 at max. speed setting [point (2)];

4.1.3.1.3 80 % of power obtained in 4.1.3.1.1 with governor control set to 90 % of rated engine speed [point (3)];

4.1.3.1.4 40 % of power obtained in 4.1.3.1.1 with governor control set to 90 % of rated engine speed [point (4)];

4.1.3.1.5 60 % of power obtained in 4.1.3.1.1 with governor control set to 60 % of rated engine speed [point (5)];

4.1.3.1.6 40 % of power obtained in 4.1.3.1.1 with governor control set to 60 % of rated engine speed [point (6)].

#### 4.1.3.2 Additional power take-off ratio (economy)

Where an alternative power take-off gear ratio is available that is designed to give standard power take-off speed at lower engine speeds for the benefit of better fuel economy, the power it generates may be measured subject to the following minimum requirements:

##### 4.1.3.2.1 Test Requirements

Maximum power shall be measured at a speed equivalent to rated engine speed and at the engine speed giving the standard power take-off speed.

The governor lever shall be set to give maximum power at standard power take-off speed and the tests shall be run at a suitable time during the main power take-off tests. To maintain consistency of measurement for comparison purposes, test conditions shall match those prevailing during the measurement of the equivalent points on the main power take-off test.

##### 4.1.3.2.2 Test Results

The test results shall be displayed adjacent to those of the main power take-off test in the specimen test report for the purpose of easy comparison.

#### 4.1.4 Special case of tractors with a power take-off unable to transmit the full power of the engine

Tests at the main power take-off are made when the main power outlets can transmit the total available power.

Alternatively, when the power take-off cannot transmit the full power, a full power test shall be made at the engine crankshaft. In such cases, the power take-off shall still be tested, depending upon the type of coupling as follows:

##### 4.1.4.1 Mechanical coupling between engine and power take-off

The power take-off test will be made consisting of a two-hour test at the maximum power specified by the manufacturer with a 20 per cent increase in torque applied every five minutes for a period not exceeding one minute. If the engine does not develop the 20 per cent increase in torque the intermittent overload shall be carried out at maximum engine torque. This fact shall be noted in the test report. In either case the maximum power take-off power reported for the two-hour test will be that specified by the manufacturer.

##### 4.1.4.2 Non-mechanical coupling between engine and power take-off

This will be the case of a fluid or electrical power transmission system with its possible cooling component. The following test conditions and procedures shall apply:

#### 4.1.4.2.1 Test Requirements

In addition to those required under 4.1.4.1 above, a means shall be provided for measuring the temperature of any non-mechanical components which couple the engine to the power take-off system.

#### 4.1.4.2.2 Test procedure

The governor control lever being set for maximum power, the system shall be operated at maximum power take-off power for a period sufficient to establish stabilised conditions but not less than two hours. The power take-off system shall be considered stable when two consecutive temperature readings of the cooling device taken 10 minutes apart do not differ by more than 1°C.

The tractor shall then operate for a period of one hour. The maximum power quoted in the report shall be the average of a minimum number of six readings to be evenly spread. If the power take-off or the engine speed deviates by more than 2 per cent from the standard power take-off speed or calculated average speed respectively, the test shall be repeated. If the variation continues, the deviation shall be stated in the report. The temperature observed at the critical components of the system shall also be recorded.

A second one-hour test shall be made at the power take-off power level observed above and at the lowest engine speed which will maintain this power at the rated power take-off speed.

A third series of tests shall determine power take-off power at part loads with the governor control set as for the second test. Each test shall last at least 20 minutes and shall be made according to 4.1.1 above.

### 4.1.5 Performance at the belt or the belt pulley shaft

#### 4.1.5.1 Test Requirements

The tractor pulley shall be connected to that of the dynamometer bench by a belt. This belt shall be flexible and have appropriate power and torque transmission characteristics. Belt slip shall not exceed 2 per cent and the necessary tension to obtain this condition shall be as small as possible.

The tests at the pulley shaft shall be conducted by directly coupling the tractor pulley to the dynamometer shaft.

All of the provisions for tests at the main power take-off shall apply to the belt tests and to the pulley shaft tests, with the exception of those at standard power take-off speed and for tractors unable to transmit the full engine power at the power take-off.

If the engine speed recommended by the manufacturer for tests at maximum power does not correspond to a standard belt speed, the operational characteristics of the engine at the speed corresponding to the standard belt speed shall be measured during the full load test.

#### 4.1.5.2 Test results

The power, belt slip, hourly fuel consumption and specific fuel consumption in relation to engine speed shall be recorded, as in the main power take-off test.

#### 4.1.6 Performance in a hot atmosphere

##### 4.1.6.1 Test Requirements

These tests must be made at a temperature regulated to  $\pm 2^{\circ}\text{C}$ . The tractor is coupled to a dynamometer bench as in the power take-off tests.

During the tests the following temperatures are taken: water temperature at the cylinder block before the thermostat or, in the case of an air-cooled engine, temperature at the point prepared by the engine manufacturer to hold the temperature sensing device; air temperature at the cooling system inlet; engine oil temperature; air temperature at the air cleaner inlet; fuel temperature.

##### 4.1.6.2 Test procedure

A first series of tests takes place with the governor control lever set for maximum power at the rated speed of the engine.

The temperature of the cooling system and of the engine oil, at maximum engine power and under stable conditions, are recorded as a function of the ambient temperature which will be taken as being the temperature of the air entering the cooling system.

Before taking readings, all temperatures must be stabilised. The ambient temperature limit for running the tractor is the temperature at which the engine achieves its temperature limit in running, determined either by the boiling of the cooling water or by obtaining the maximum temperature at the insertion point of the safety thermostat specified by the manufacturer, or yet again by obtaining the maximum temperature fixed by the manufacturer for the engine oil.

The approximate value of the ambient temperature limit is worked out graphically by extrapolating the engine temperature curves (cooling system or oil temperature).

##### 4.1.6.3 Test Results

The power loss is determined in the same way, being expressed as a percentage of maximum power obtained in the main power take-off tests. If the power take-off speed at maximum power is more than 25 per cent greater than at standard speed, the test shall be repeated at that speed.

#### 4.1.7 Low Temperature Starting Test

##### 4.1.7.1 Test Requirements

The test shall determine the lowest temperature at which the engine is able to start or provide verification of the manufacturer's claim on this point. The only energy source allowed for use before and during the start attempts is the battery of the tractor.

###### 4.1.7.1.1 Fuel

The complete fuel system shall be filled with the appropriate grade of fuel for operation at the test temperature. If prior to the test the engine has been operating on another fuel, new filter elements shall be fitted and care shall be taken to drain the fuel from all components of the fuel system, to flush and fill it with the appropriate test fuel, and finally to run the engine to ensure that the system is free of air.

The following data on the fuel used shall be recorded: type, density at 15°C, octane or cetane number and pour-point following the guides of ISO 3016:1994 (pour-point), ISO 5164:1990 (octane number research), ISO 5163:1990 (octane number motor), ISO 5165:1998 (cetane number) and ISO 3675:1998 (density).

#### 4.1.7.1.2 Lubricating oil

The engine and transmission lubricating systems shall be filled with the appropriate grade of oil for operation at the test temperature. If prior to the test the tractor has been operating with grades of oil appropriate to other temperatures, care shall be taken in draining these, flushing and filling with the appropriate oils. The oil levels shall be checked after running the engine for a few minutes and topped up if necessary before commencing the test. The grade of oil used shall be recorded.

#### 4.1.7.1.3 Starting systems

\* Electrical

The batteries (original batteries and spare batteries of same model and type) shall be fully charged. Battery terminals and leads shall be checked for good condition;

\* Potential energy storage types (mechanical, hydraulic, etc.)

Where appropriate two tests shall be carried out. In one the storage system shall be charged before the soaking period, and in the other it shall be charged immediately prior to the starting attempts if this is possible.

#### 4.1.7.1.4 Cooling system

With water-cooled systems antifreeze solution of the appropriate strength shall be used.

#### 4.1.7.1.5 Starting aids

All systems to aid starting shall be checked for correct operation before the start of the test. At least one test shall include a starting trial without using any external energy sources, either electrical, mechanical or hydraulic. Upon request, additional trials can be made with starting aids recommended by the manufacturer. Aids used shall be recorded.

#### 4.1.7.2 Test procedure

The tractor shall be placed and maintained in an environment held at the test temperature until all temperatures are stabilised. The temperatures are considered to be stable when they vary less than 2°C in one hour.

The temperature of fuel, engine oil and transmission oil shall be measured in the middle of the tanks with fuel tanks full and oils at the recommended level. The temperature of the coolant shall be measured at the top of the radiator.

The temperatures in the environment shall be measured at four points around the tractor or, if that is impossible, at half the distance between the tractor and the chamber wall and at the level of the engine crankshaft centre. The temperature variations between the tractor and the four points must not be more than 1°C. No starting attempts are allowed until two hours after all temperatures are stabilised at the test temperature.

Spare test batteries (to be used during subsequent tests) must be soaked to test temperature together with the tractor and they must be kept in the environment until the test is completed.

If no spare batteries are available, the test battery(ies) shall be moved to a temperate environment after each test to be fully charged and then allowed to soak with the tractor at the new test temperature.

Starting shall be attempted using the normal procedure recommended by the manufacturer. A start shall be deemed successful when the engine runs with engine speed controlled by the governor within 30 seconds after the starter begins to crank, without aid from the starter and thermal device. In this test five attempts without charging the battery(ies) within a period of five minutes are permissible.

If the five attempts are unsuccessful, the tractor shall be started at an ambient temperature allowing its start up and run for a period of at least 15 minutes. The test procedure will then be repeated at a higher temperature. If on the other hand, the engine starts, the same procedure may be followed at a lower temperature. The entrant shall determine the need for additional tests, and the temperature(s) at which they are conducted. The process shall be repeated until the lowest temperature at which the engine is able to start is found. If the manufacturer does not require a specific starting temperature, the test will begin using minus 15°C. If needed subsequent steps will be plus or minus 2.5°C.

The entrant shall have the option to nominate his operator for starting attempts.

## **4.2 Hydraulic Power**

### **4.2.1 Test Requirements**

For all tests:

The hydraulic fluid shall be as recommended by the manufacturer and identified by type and viscosity in accordance with ISO 3448:1992.

At the start of each test, the temperature of the hydraulic fluid in the tractor hydraulic reservoir shall be at  $65\text{ }^{\circ}\text{C} \pm 5\text{ }^{\circ}\text{C}$  and be recorded. If this cannot be achieved, due to the presence of an oil cooler or other system component, the temperature measured during the test shall be stated in the test report.

Tractor-mounted flow controls shall be adjusted to obtain maximum flow.

#### **4.2.1.1 Compulsory Tests (Section 4.2.2)**

They shall be conducted with the throttle or governor control lever adjusted to the maximum engine speed condition. The engine speed is recorded during the tests.

For tests conducted at maximum engine speed, the engine speed is continuously recorded during the tests.

#### **4.2.1.2 Supplementary Tests (Section 4.2.3)**

They are available in order to provide additional information relative to the hydraulic system performance characteristics. These tests are at the discretion of the manufacturer and can be individually selected (any combination of the optional tests can be selected by the manufacturer).

For tests conducted at rated engine speed, the throttle or governor control lever shall be adjusted to maintain the rated engine speed within the tolerance limits as specified.

The auxiliary service couplings, measurement equipment, and associated definitions shall be in accordance with ISO 789-10:1996.

#### 4.2.2 Compulsory steady state hydraulic pressure, flow, and power test - maximum available power

The following results shall be reported:

- the maximum hydraulic pressure sustained by the open relief valve, with the pump stalled in the case of closed-centre system with pressure-compensated variable delivery pump; (see ISO 789-10:1996 section 4.1);
- the hydraulic power available at the auxiliary service coupling, at the flow rate corresponding to a hydraulic pressure equivalent to 90 per cent of the actual relief valve pressure setting in the circuit;
- the maximum available hydraulic power test with flow through a single coupler pair, and corresponding flow and available coupler outlet pressure (pressure near coupler where oil is exiting from tractor);
- the maximum available hydraulic power test with coupler pairs operating simultaneously (flow through two or more coupler pairs if required), and corresponding flow and available coupler outlet pressure (pressure near coupler where oil is exiting from tractor). If the maximum hydraulic power is obtained with one coupler pair, this test is not required.

#### 4.2.3 Supplementary steady state hydraulic pressure and flow tests - maximum usable power, maximum available differential pressure, peak pressure, and sump return pressure

The following results shall be reported:

- the maximum usable (continuous) hydraulic power test with flow through a single coupler pair, and corresponding flow and available differential pressure (pressure near coupler where oil is exiting from tractor - pressure near coupler where oil is re-entering the tractor, see ISO 789-10:1996, section 7.2.1);
- the maximum usable (continuous) hydraulic power test with flow through two (or more if required) coupler pairs operating simultaneously, and corresponding flow and available differential pressure (pressure near coupler where oil is exiting from tractor - pressure near coupler where oil is re-entering the tractor, see ISO 789-10:1996, section 7.2.2);
- the maximum available differential pressure with flow through a single coupler pair (30 l/min - category 1, see ISO 789-10:1996, section 4.1.2.1);
- the maximum available differential pressure with flow through a single coupler pair (50 l/min - category 2 & 3, see ISO 789-10:1996, section 4.1.2.1);
- the maximum pressure ("peak pressure") observed during the cylinder extended portion of 15 cycles of cylinder movement. (see ISO 789-10:1996, section 4.2);

- the hydraulic pressure with flow into sump return port with coupler (30 l/min - category 1, 50 l/min - category 2 & 3, see ISO 789-10:1996, section 4.1.2.2);
- the hydraulic pressure with flow into sump return port without coupler (30 l/min - category 1, 50 l/min - category 2 & 3, see ISO 789-10:1996, section 4.1.2.3).

### 4.3 *Hydraulic Lift*

#### 4.3.1 Test Requirements

The tractor shall be so secured that the reactive force of the power lift deflects neither tyres nor suspension. The linkage shall be adjusted in the same way both with and without the coupled frame to achieve typical arrangements as follows:

- the linkage shall be adjusted in accordance with the tables in ISO 730-1:1994 + Cor 1:1995 and ISO 730-2:1979. For those tractors which do not achieve the standard power range, the lift force will be measured at the maximum achievable power range;
- the upper link shall be adjusted to the length necessary to bring the mast of the frame vertical when the lower links are horizontal;
- where more than one upper or lower link point is available on the tractor, the points used shall be those specified by the manufacturer and shall be included in the test report;
- where there is more than one attachment point to connect the lift rods to the lower links, the connection points used shall be those specified by the manufacturer and shall be included in the test report;
- these initial adjustments, as far as possible, shall cause the mast to turn through a minimum of 10° from the vertical to the angle at which the frame is in the uppermost position. If this is not possible, the fact shall be stated in the test report;
- the oil pressure shall be checked during the test.

#### 4.3.2 Lift at the lower hitch points

An external vertical downward force shall be applied to a horizontal bar connecting the lower hitch points. This force shall remain as vertical as possible in the median plane of the tractor throughout the lift range. If necessary, the values of measurement will have to be corrected.

The lifting force available and the corresponding pressure of the hydraulic fluid shall be determined at a minimum of six points approximately equally spaced throughout the range of movement of the lift, including one at each extremity. At each point the force shall be the maximum which can be exerted against a static load. Additionally, the range of movement shall be reported. The pressure recorded during the test must exceed the minimum relief valve pressure setting.

The values of force measured shall be corrected to correspond to a hydraulic pressure equivalent to 90 per cent of the actual relief valve pressure setting of the hydraulic lift system. The corrected value of the lowest lifting force constitutes the maximum vertical force which can be exerted by the power lift throughout its full range of movement.

#### 4.3.3 Lift on a coupled frame

A frame having the following characteristics shall be attached to the three-point linkage:

The mast height and the distance from the hitch points to the centre line of the tractor shall be appropriate to the linkage category (as defined by ISO 730 in 4.3.1 above). Where more than one category is specified, that chosen for the test shall be at the manufacturer's option.

The centre of gravity shall be at a point 610 mm to the rear of the lower hitch points, on a line at right angles to the mast and passing through the middle of the line joining the lower hitch points.

Testing conditions and procedure shall be as in 4.3.2 above. The weight of the frame shall be added to the force applied.

#### 4.3.4 Test results

The following results shall be reported:

- the maximum corrected vertical force at the lower hitch points and at the centre of gravity of the standard frame as a function of the lifting heights measured with respect to the horizontal lower links for the whole range of movement of the lift;
- the full range of vertical movement of the respective points of application of the force;
- the pressure equivalent to 90 per cent of the actual relief valve pressure setting;
- the pressure corresponding to maximum power delivered by the hydraulic system;
- the height of the lower hitch points above the ground in their lowermost position and without load;
- the angle through which the mast turns from the vertical to the uppermost position;
- the main linkage dimensions and the mast height of the frame relative to the centre line of the rear wheels as tested;
- the temperature of the hydraulic fluid at the start of each test;
- the calculated moment around the rear wheel axis, resulting from the maximum external lift force at the frame which can be exerted through the full range of movement.

### **4.4 *Drawbar Power and Fuel Consumption***

#### 4.4.1 Information about tests

##### 4.4.1.1 Tyres and tracks

Tests may be carried out on one or more sets of tyres of different sizes, and the several results included in the test report. However, one of the tests only may be selected for inclusion in the compulsory section of the test report.

#### 4.4.1.2 Tread Bar Height

At the beginning of the drawbar tests, the height of the tyre or rubber track tread bars shall not be less than 65 per cent of the height of the bars of the tyres or tracks when new. The height of the tyre tread bars shall be measured by use of a three-point gauge. The gauge shall be placed astride the tread bar and perpendicular to the direction of the tread bar as close to the centre line of the tyre or track as possible. Two legs of the gauge shall be positioned at the base of the tread bar (at the point of tangency between the tyre or track carcass and the radius joining the tread bar to the carcass). The third point of the gauge shall be in the centre of the tread bar. The tread bar height shall be the difference in elevation between the two outside legs of the gauge and the centre point. The tread bar height measured in this manner shall be taken and averaged for a minimum of four equally spaced locations round the periphery of the tyre or track. It shall be compared to similar data on a new tyre or track of the same make, size and type.

#### 4.4.1.3 Ballasting (Not for 4.4.2)

Ballast weights may be fitted. For tractors having pneumatic tyres, liquid ballast in the tyres may also be used; the overall static weight on each tyre (including liquid ballast in the tyres and a 75 kg weight representing the driver), and the inflation pressure shall be within the limits specified by the tyre manufacturer, except as specified for the five-hour test (see 4.4.4 below).

#### 4.4.1.4 Test track, treadmill or axle dynamometer

The tests at the drawbar shall be conducted according to the following regulations in order to provide reasonably comparable results in all countries.

The tests shall be carried out on a clean, horizontal, and dry concrete or tarmacadam surface containing a minimum number of joints.

Tractors that are not suitable for operation on concrete or tarmacadam surfaces, such as steel-wheeled or steel-tracked tractors shall be tested on flat, dry and horizontal, mown or grazed grassland, or on a horizontal track having equivalent adhesion characteristics.

A moving track (treadmill) may also be used subject to the condition that results produced are comparable to those obtained on the surfaces mentioned above.

An axle dynamometer may also be used for the optional test according to ISO 789-7:1991 (see 4.4.7 below).

The type of test track shall be clearly stated in the report.

#### 4.4.1.5 Gears (definition)

Conventional gearboxes, which have mechanically fixed ratios, i.e. 'gears', selectable either manually or electro-mechanically for example, can only be tested within the limits of those fixed transmission ratios.

Some other gearboxes however, can have fully or partially non-mechanical stepless transmission systems.

If it is possible to select and sustain a transmission ratio on such a gearbox by the controls available to the driver in normal work, for testing purposes such ratios or 'speed settings' may be

considered the same as fixed gears. For a test, those controls may be used to select a sufficient number and spread of gears/speed settings over the performance range of the tractor to adequately reflect the performance envelope. At least 7 gears/speed settings ranging from 2.5 km/h to 17.5 km/h (or stopping at the gear/speed setting where maximum drawbar power is developed) shall be tested.

In tests using this method, the ratios chosen will also be known as 'gears' or 'speed settings' and tests will be carried out according to 4.4.2 below.

#### 4.4.1.6 Drawbar

The line of draught shall be horizontal. The height of the drawbar shall remain fixed in relation to the tractor during each test. It shall be chosen by the manufacturer in such a way that the direction of the tractor can be controlled when it develops maximum drawbar pull.

In the case of wheeled tractors, the following relationship shall be maintained:

$$PH \geq 0.8 WZ, \text{ where:}$$

**P** is the maximum drawbar pull;

**H** is the static height above ground of the line of draught;

**W** is the static weight exerted by the front wheels on the ground; and

**Z** is the wheelbase.

When testing four-wheeled drive tractors with a differential connection between driving axles, the drawbar height must be selected so as to keep adhesion consistent between front and rear wheels when the drawbar pull reaches its maximum.

#### 4.4.1.7 General Test Requirements

During all the tests at the drawbar, the governor control shall be set for maximum power except where instructed in 4.4.2.1 below. Tests shall not be made in gears or speed settings in which the forward speed will then exceed the safety limits of testing equipment.

For each gear or speed setting, at the speed and pull giving maximum power in that gear/speed setting, there shall be recorded the engine speed, power, drawbar pull, speed, slip of wheels or tracks, fuel consumption (where specified by the test), temperature of fuel, coolant and lubricating oil and the atmospheric conditions.

During tests the ambient temperature shall not exceed 35°C.

In the case of wheeled tractors performance values only up to 15 per cent mean wheel slip shall be reported. As the no-slip distance will vary according to the degree of wear of the tyres it will be necessary to check this regularly, particularly before determining maximum drawbar power. With track-laying tractors the maximum drawbar pull, together with the corresponding track slip, and also the point corresponding to a track slip of 7 per cent or more shall be stated as a footnote beneath the table giving drawbar power values.

If possible, tracklaying tractors can be tested on a dry concrete or tarmacadam surface. In such a case, test procedure and conditions shall be those applicable to wheeled tractors.

4.4.1.8 Transmissions not mechanically linked to the engine and automatic / steplessly variable transmissions

- Non mechanically linked

If the tractor is equipped with a hydrokinetic torque converter fitted with a "lock-out" device, which is controlled by the driver, the drawbar tests shall be carried out in succession with the multiplier in operation and with the multiplier locked out.

- Steplessly variable / fully automatic

In the case of tractors with a steplessly variable transmission, it may not be possible to record the maximum power in the chosen gear ratios or with a particular 'speed setting'. The drawbar power envelope curve shall be obtained by determining the maximum power and fuel consumption figures for a sufficient number of transmission ratios to enable an accurate envelope curve to be drawn. Power values shall then be derived from this envelope at least at the following speeds:

**Note:** Drawbar power output at additional forward speeds may be included at the discretion of the testing station.

Wheeled and comparable tractors:							
km/h	2.5	3.5	5.0	6.5	8.0	11.0	17.5
Steel-wheeled and steel-tracked tractors:							
km/h	1.5	2.5	3.5	5.0	6.5	8.0	10.0

In addition, the following data derived from the curve shall be reported:

- Maximum power, fuel consumption and corresponding speed;
- Maximum power and corresponding drawbar pull with travelling speed control and engine governor control in the position giving maximum speed.

4.4.2 Drawbar power and fuel consumption test, unballasted tractor

4.4.2.1 Drawbar power tests will determine the power available at the drawbar of the unballasted tractor over a range of different gears/speed settings.

Tests shall be made at least in those gears/speed settings, from one giving a travel speed immediately faster than in the gear/speed setting in which the greatest maximum power is developed down to one immediately slower than the gear/speed setting allowing maximum pull to be developed.

In the case of tractors with a steplessly variable transmission, instead of different gears with fixed ratios, at least 7 evenly spaced forward speeds/ratios (see 4.4.1.8 above) shall be selected in order to obtain results in the range 2.5 km/h to 17.5 km/h.

4.4.2.2 Fuel consumption test during the drawbar power test

In order to provide information on operational efficiency at part loads, fuel consumption will be measured in two gears/speed settings typically used for fieldwork. One of which shall have a nominal speed of 7.5 km/h (or a gear / speed setting giving a nominal speed nearest to that target) and the other

giving a nominal speed between 7 and 10 km/h, chosen by the manufacturer in agreement with the testing station.

Measurements must be made at:

- 4.4.2.2.1 maximum drawbar power available in the selected gear/speed setting at rated speed;
- 4.4.2.2.2 a pull equal to 75 per cent of the pull corresponding to maximum power at rated speed;
- 4.4.2.2.3 a pull equal to 50 per cent of the pull corresponding to maximum power at rated speed;
- 4.4.2.2.4 reduced engine speed in a higher gear/speed setting, which is able to develop the same pull and travelling speed as in 4.4.2.2.2;
- 4.4.2.2.5 reduced engine speed in the same gear/speed setting used in 4.4.2.2.4 with the same pull and travelling speed as in 4.4.2.2.3.

With some small tractors and certain automatic or stepless transmissions, 4.4.2.2.4 or 4.4.2.2.5 may be impossible. This fact must be stated in the test report.

In the case of tractors incorporating a control mode with automatic common engine speed and transmission control, this automatic mode may be used.

#### 4.4.3 Additional drawbar tests

Following exactly the instructions in the drawbar test above, a second test series may optionally be performed on the tractor, ballasted (see 4.4.1.3 above) or with different tyres for example in accordance with the manufacturer's specifications. The number of such optional tests is not limited.

It is not necessary to record fuel consumption or to measure part loads when a full unballasted test has already been carried out.

#### 4.4.4 Ten-hour test (ballasted tractors)

##### 4.4.4.1 Test Requirements

This test could be carried out only if an additional drawbar test with the tractor ballasted (section 4.4.3) has been performed. It shall consist of two five-hour tests in succession.

Values of power, pull, forward speed and slip shall be included in the report. Fuel consumption shall only be included in the report for the test under section 4.4.4.2 below.

In the case of tractors fitted with a hydrokinetic torque converter that can be locked out by the driver, the test shall be carried out with the torque converter in operation, within the limitations specified by the manufacturer in his published instructions. If the limiting conditions are reached, the test shall be completed with the torque multiplier out of operation; the respective duration of the two parts of the test shall be noted in the report and the fuel consumption separately stated.

During the ten hours of these two tests the engine lubricating oil consumption shall be measured and expressed in units of mass per hour.

4.4.4.2 The ballasted tractors shall be tested for 5 hours in the gear/speed setting designated by the manufacturer, in agreement with the testing station.

This speed shall be one normally used for basic agricultural work such as ploughing but as far as possible a different gear group from that used in 4.4.4.3 below.

The drawbar load applied shall be 75 per cent of the pull corresponding to maximum power at rated speed in the selected gear/speed setting.

4.4.4.3 Following test 4.4.4.2 above, with a cooling interval between, tractors will be tested for a further five hours at the drawbar pull giving at most 15 per cent wheel slip measured during test 4.4.3 above. The gear/speed setting used shall be the fastest in which the required pull can be obtained when the engine is operating under the control of the governor.

It may be necessary to add supplementary ballast to reduce tyre wear and to have proper control of the tractor, within the load limitations specified by the manufacturer for this test.

#### 4.4.5 Ten-hour test for the special case of steel-wheeled or steel-tracked tractors

For steel track-laying and steel-wheeled tractors one test of ten hours shall be made as otherwise specified in 4.4.4.2. This test shall be carried out in two five-hour periods, with a cooling interval in between.

#### 4.4.6 Drawbar power and fuel consumption tests for the special cases of tractors without a power take-off or with a power take-off unable to transmit the full power from the engine

In those cases when a tractor is not equipped with a power take-off or when the power take-off is not permitted to transmit the full power of the engine (see 1.2 above), the engine may be tested in accordance with section 4.1.2. If the engine is not tested, or as an option requested by the manufacturer, the following series of drawbar tests under either unballasted or ballasted conditions shall be performed:

4.4.6.1 A two-hour test at maximum power in a gear/speed setting chosen by the test station in agreement with the manufacturer within the range of gears from the lowest gear/speed setting, which allows the maximum power of the engine to be utilised to the highest gear/speed setting, which allows a controllable test to be performed by the test station. The gear/speed setting chosen must also allow to carry out the test according to 4.4.6.2 down to a speed where maximum drawbar pull occurs within maximum 15 per cent wheelslip. During this test, engine revolutions, fuel consumption, travel speed, slip, drawbar pull and relevant temperatures and pressures shall be monitored, and recorded at least every ten minutes. In addition, fuel temperature must be maintained throughout the test. The maximum drawbar power shall be the average of the readings made during the two-hour period. If the power deviates by more than 2 per cent from the average, the tests shall be repeated. If the variation continues, the deviation shall be stated in the report.

4.4.6.2 A test at full load and at varying engine speed (also called a "lugging run") shall be carried out with all adjustments the same as for the regular drawbar tests and PTO tests. Drive member slip shall be limited to 15 per cent and data recorded shall be the same as for the other drawbar tests. The gear/speed setting shall be the same as that used in test 4.4.6.1.

Tractors with a torque converter or torque multiplier that can be locked out shall be operated in both unlocked and locked mode. Tractors with automatic downshift systems shall be tested until the first downshift occurs. Section 4.4.6.2 may not apply to tractors with infinitely variable shift systems.

4.4.6.2.1 A series of test runs shall be made starting at maximum power at rated engine speed. The drawbar load shall be stepwise increased resulting in a decrease of engine speed at 100-rpm increments. The test steps shall continue until maximum pull is obtained, or other limitations such as cooling capacity of the engine or torque converter (if equipped), or any other limitation stated by the manufacturer.

4.4.6.2.2 A part-load test shall be made at 75 per cent of pull obtained at rated engine speed.

4.4.6.2.3 A second part-load test shall be made at 50 per cent of pull obtained at rated engine speed.

#### 4.4.6.3 Graphical presentation of results

The test report shall include presentation of the following curves made for the full range of engine speeds available:

- Drawbar power as a function of engine speed;
- Increase in pull as a function of engine speed;
- Hourly and specific fuel consumption as a function of engine speed.

#### 4.4.7 Axle power determination

Test conditions, procedures and reporting shall be subject to the general provisions of the Codes. The test method shall follow ISO 789-7:1991.

### 4.5 *Turning Area and Turning Circle*

The turning area and turning circle may be determined as shown in 4.5.1 and 4.5.2 below or, for non-track-laying tractors, according to the conditions and procedures used in ISO 789-3 :1993 *Agricultural Tractors - Test Procedures - Part 3: Turning and Clearance Diameters*.

The radii of the turning area and turning circle will be reported as shown in the OECD specimen test report.

#### 4.5.1 Test Requirements

These measurements shall be made on the same type of test track as would be used for the test at the drawbar. The track setting shall be one commonly used in the country undertaking the test. Front and rear track settings shall be as nearly as possible the same and shall be recorded. The tractor shall be unballasted and moving slowly (approximately 2 km/h).

#### 4.5.2 Test procedure

Tests shall be made turning right and left, without using the steering brakes.

Measurements on four-wheel-drive tractors whose front-wheel-drive can be disengaged shall be performed only without front-wheel drive.

Tractors which have front and rear steering wheels and which have devices for disconnecting the steering of one or both axles shall be tested in the configuration which provides the smallest radius. Other steering combinations can be tested at the option of the testing station.

For track-laying tractors which can turn on the spot and thus have no measurable turning circle, the radius of the turning area only shall be reported. This shall be the distance from the centre of rotation to that point on the tractor that describes the largest circle.

#### **4.6 Centre of Gravity**

The test conditions and procedures outlined in ISO 789-6:1982 *Agricultural Tractors - Test Procedures - Part 6: Centre of Gravity* and its amendment Amd 1:1996 may be used to determine the position of the centre of gravity of the test tractor.

This shall be determined with full tanks and the driver replaced by a weight of 75 kg on the driver's seat, the tractor being otherwise unballasted.

#### **4.7 Braking**

##### **4.7.1 General Test Requirements**

The performance of service braking devices shall be based on the mean deceleration calculated over the stopping distance. The stopping distance shall be the distance covered by the tractor from the moment when the driver begins to actuate the control of the device until the moment when the tractor stops.

The performance of the parking braking devices shall be based on the ability to hold the tractor stationary, facing up and down slopes.

The braking performance shall be measured during road tests conducted under the following conditions:

- The tractor mass shall be as prescribed for each type of test and be specified in the test report;
- The braked axle wheels shall be fitted with the highest load capacity tyres used in normal agricultural work;
- The road shall have a surface affording good adhesion;
- The test shall be performed when there is no wind liable to affect the results;
- At the start of the tests the tyres or rubber tracks shall be cold. The pressure in the tyres or the track drive and suspension system shall be as prescribed for the load actually borne by them when the tractor is stationary.

The performance shall be measured without locking the brakes.

During the tests the tractor shall be fitted with any parts intended by the manufacturer for the operation of towed vehicle braking devices.

##### **4.7.2 Braking Tests**

###### **4.7.2.1 Cold service braking device test**

### Test Requirements

The brakes must be cold at the beginning of the test. A brake is deemed to be cold if any of the following conditions is met:

- the temperature measured on the disc or on the outside of the drum is below 100°C;
- in the case of totally enclosed brakes, including oil immersed brakes, the temperature measured on the outside of the housing is below 50°C;
- the brakes have not been actuated for one hour.

During the braking test, an unbraked axle, when capable of being declutched, shall not be connected with a braked axle.

The test shall be conducted under the following conditions:

- the tractor shall be ballasted to its maximum mass with an unbraked axle also loaded to its technically permissible maximum mass; for tractors braking on all wheels, the front axle shall be laden to its technically permissible maximum mass;
- the test shall be repeated on the unballasted tractor carrying only the driver and, if necessary, a person responsible for monitoring the results of the test;
- the road shall be level.

### Test Procedure

With the tractor travelling at its maximum speed or 50 ± 5 km/h, whichever is less, a measured force shall be applied to the control of the service braking device and the resulting stopping distance measured.

Where possible the engine shall be declutched when starting to apply the brakes. If this is not possible, the engine speed control shall be moved to the minimum engine speed position.

### Test Results

The stopping distance for a series of values of force applied to the control of the braking device shall be recorded and the corresponding values of mean deceleration calculated from the following formula:

$$f = V^2/2S, \text{ where}$$

**f** is the mean deceleration (m/s<sup>2</sup>);

**V** the initial speed (m/s);

**S** the stopping distance (m).

Sufficient values shall be obtained to establish the relationship between mean deceleration and force applied to the control of the braking device.

The force shall vary between zero and, if possible, the force at which the brakes lock. If the brakes do not lock, the effect of pedal forces up to 600 N shall be recorded.

Additionally, the minimum stopping distance obtained without locking the wheels shall be reported along with the corresponding initial speed and braking control force.

Deviation of the tractor from its original course and any abnormal vibration during braking shall also be reported.

### **Graphical Presentation**

The relationship between mean deceleration and force applied to the control of the braking device shall be reported in the form of a graph and a table of corresponding values.

#### 4.7.2.2 Fade test

### **Test Procedure**

As a first method, the tractor shall be towed for 1 km at  $80 \pm 5$  per cent of its maximum speed with, if possible, the engine disengaged from the driven axles and the service brake applied such that the towing force is 10 per cent of the maximum tractor weight.

As an alternative, the tractor shall be driven for 1 km at  $80 \pm 5$  per cent of its maximum speed. The service brake shall be actuated with that force which had given a mean deceleration of  $1 \text{ m/s}^2$  in the preliminary brake tests with cold brakes. The governor control lever has to be set at the start of the drive. The initial speed shall be maintained throughout the drive by actuation of the service brake.

Immediately after heating the brakes by whichever of the above two procedures is appropriate, the cold service braking device test shall be repeated without allowing the brake to cool and omitting measurements with the tractor unballasted.

The report shall state which method of heating the brakes was used.

#### 4.7.2.3 Parking braking device test

The tractor shall be ballasted to its maximum weight. The force which it is necessary to apply at the control of the parking braking device to hold the tractor stationary when facing up and down an 18 per cent gradient shall be measured.

The measurements may be made either on a sloping road or by applying a pull to the tractor on a level road.

If it is necessary to actuate the parking braking device control several times in order to hold the tractor stationary, the maximum force applied shall be recorded.

## **4.8 External Noise Level**

### 4.8.1 Test requirements

#### 4.8.1.1 Measuring equipment

A precision quality sound level meter shall be used meeting the requirements of the International Electrotechnical Commission Standard IEC 60651:1979 *Sound level meters* + Am1:1993 + Am2:2000. Measurement shall be carried out with a frequency weighting network in conformity with curve A and set to give fast response as is described in the IEC publication.

The equipment shall be calibrated frequently and, if possible, before each measuring session. An adequate technical description of measuring equipment shall be given in the test report.

#### 4.8.1.2 General requirements

Measurement will be made on the unballasted tractor with no load, in a sufficiently silent and open zone (ambient noise and noise of wind 10 decibels less than the noise to be measured). For example, this zone may be an open space of 50 m radius, of which the central part of at least 20 m radius shall be practically level and made of concrete, asphalt or similar material and shall not be covered with powdery snow, high grass, friable soil or cinders.

The surface of the track shall be of such a kind that pneumatic tyres do not cause excessive noise.

Measurements shall be made in fine weather with little or no wind. Any extraneous noise occurring during the reading, which is not connected to general sound level measurement, shall not be taken into consideration.

#### 4.8.1.3 Stabilised speed to be used

The stabilised speed to be used will be equal to three-quarters of the attainable maximum in the gear giving the highest speed used for roadwork.

#### 4.8.2 Noise level test

At least two measurements shall be carried out on each side of the vehicle. Preliminary measurements to establish governor control setting may be made but shall not be taken into consideration.

The microphone shall be placed 1.2 m above ground and at a distance of 7.5 m from the axis of forward movement of the vehicle, measured along the perpendicular **PP'** to this axis.

Two lines **AA'** and **BB'**, parallel to the line **PP'** and situated respectively 10 m in front and behind this line, shall be marked on the test track. Vehicles shall be driven at stabilised speed, under the conditions specified above, as far as line **AA'**. At this moment, the governor control lever shall quickly be fully opened. The lever shall be held in this position until the vehicle has passed line **BB'** and then brought to the minimum position as quickly as possible.

Measurements shall be considered valid if the difference between (the) two consecutive measurements on the same side of the vehicle is not greater than 2 decibels. The value shall be that corresponding to the highest sound level.

### 4.9 *Waterproofing Test*

#### 4.9.1 General

The waterproofing test is applied to wheeled or track-laying tractors to be used in the paddy field for puddling.

The primary purpose is to verify the waterproofing functions of the wheel axles, the brake assembly and the clutch assembly.

Verification can however be extended at the request of the manufacturer to other parts of tractors such as engine sump, hydraulic/transmission case and self starter that could be damaged by water penetration.

The tractor is classed as “waterproof tractor,” if after the test described below, there is no water penetration into axle, brake, clutch system or any other part submitted to the verification.

#### 4.9.2 Test conditions

##### 4.9.2.1 Test bed

The test shall be conducted in a cistern (see figure below). The tractor shall be set on the roller bed (or on a similar device) where the tractor remains safely fixed during the test. For two-wheel-drive tractors the front axle shall be driven by external means (see figure below) at the same equivalent ground speed as the rear axle.

##### 4.9.2.2 Water level

The water level shall be adjusted to the height of the centre line of the front axle (wheeled tractor) or the driven sprockets (track-laying tractor) with the tractor in a horizontal position, as if driving on a road. However, if the centre line is higher than 400 mm above ground level (in accordance with ISO 4251-1:1998) the water level shall only be raised to 400 mm above the ground level.

Potable water shall be used in the cistern.

The same tyres as described under “2.6 Tyres and track width specifications” in the specimen test report shall be fitted for the test.

#### 4.9.3 Test procedures

##### 4.9.3.1 General provisions

The tractor shall be in the gear giving the nominal forward speed nearest to 6km/h and operated continuously at rated speed for 2 hours. The tractor shall then (immediately) be removed from the cistern and any excess water shall be wiped off the outside of the axles, clutch and brake assemblies with a rag. The tractor shall be left in a place free from rain or snow for at least 12 hours before being finally checked.

The axles (including centre pivot), clutch housing, the brake assembly and any other part also optionally submitted for test shall then be disassembled and any evidence of water penetration into them shall be stated in the test report.

##### 4.9.3.2 Unsuccessful test

If the test fails, the manufacturer may ask for a repeat test of the same tractor but only once. The tractor when re-tested, shall be equipped with the same components after the seals have been changed and/or re-fixed in conformity with manufacturing specifications.

##### 4.9.3.3 Checking methods

###### 4.9.3.3.1 Non-lubricating parts (e.g. ‘dry’ brakes)

‘Dry’ type clutch housings, and similar ‘dry’ tractor components, shall be checked visually inside for water ingress as indicated by actual water or rust from oxidation.

#### 4.9.3.3.2 Oiled parts

For the tractor's parts running in oil and under test, the oil in the housing shall be checked using one or more of the following alternative methods:

- Visual method

Distinct emulsification and/or colour change of the oil shall be regarded as proof of water ingress or;

- Crackling method

When water ingress is not visually distinct, the presence of water in the lubricant shall be checked by putting a heated electric soldering iron into the oil. The presence of water crackling shall be regarded as waterproofing failure; conversely, no crackling shall be regarded as waterproofing or;

- Other methods

Other physical (e.g. centrifugation) or chemical (e.g. Karl-Fisher) standards to check if there is water in the oil are accepted.

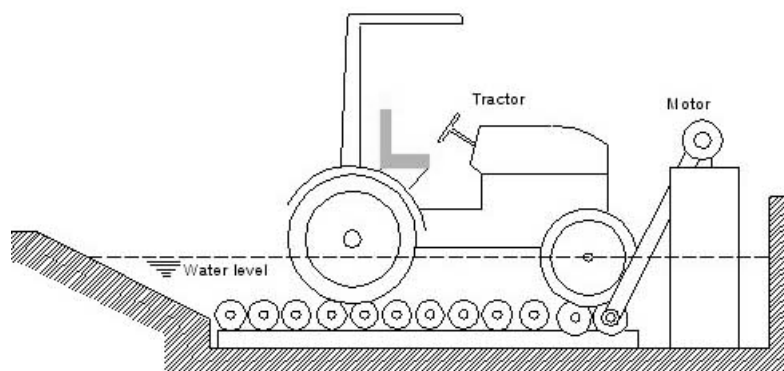

Example of cistern for waterproofing test

## 5. SPECIAL CASES

### 5.1 *Special case of testing 2-WD and 4-WD versions of the same tractor*

If, at the request of the manufacturer, 2- and 4-wheel drive versions of one tractor are tested together, the one version being modified to become the other, the same engine must be used in both and there must be no change in the transmission of power from the engine to the power take-off. Power take-off-power must be checked as well as the conformity of the second version with the manufacturer's specifications. It is then not necessary to repeat the full power take-off test. If 2- and 4-wheel drive versions of a single tractor are tested together and if positions relative to the ground are different, the lifting force of each version must be checked. If they differ by more than  $\pm 2.5$  per cent, both must be tested and a separate table for each included in the test report.

### 5.2 *Re-testing*

A testing station needs only re-test a tractor model if it has been modified so that its performance may be affected.

If the stated modifications result in changes in performance within limits set in 5.4 below, after prescribed verifications, an extension of validity of the original test report may be requested by the manufacturer.

If such an extension is not wanted, a test of the modified model may be proposed to the Station which shall ensure by a check with the OECD that no country has already carried out the relevant tractor test.

When a National Designated Authority prepares a test report for a retested tractor it must point out and report the modifications that have justified the new test.

### **5.3 *Minor modifications***

If there are minor modifications on the tractor such as changes of vehicle colour, decals, design of sheet metal parts, make or model denominations for marketing purposes, the tractor performance is not affected. Therefore the testing station which carried out the original test will issue a "Minor Modification Certificate" on the National Designated Authority's responsibility, stating all changes and confirming, after checking if applicable, that performance is not affected. This certificate shall be drafted according to the specimen provided for in the Code, as an annex to the original test report and subject to the same circulation requirements.

### **5.4 *Non-minor modifications open to validation by extension***

As opposed to minor modifications, so-called non-minor modifications are related to the engine and its components or other parts of the tractor. Tractor performance is affected.

After checking, such modifications shall result in the drafting of a new test report where they will be highlighted. The test report will be subject to the usual procedure before final printing and circulation.

#### **5.4.1 Modifications of the engine and its components**

Conditions of validation of a test report by extension are the following:

A power take-off test of the modified tractor shall have shown that all modifications did not result in a change of PTO-torque and fuel consumption measured in the original test by more than  $\pm 2.5$  per cent at manufacturer's rated engine speed and/or maximum power. Power take-off performance must remain within  $\pm 2.5$  per cent at all other engine speeds between high idle speed and maximum torque speed.

#### **5.4.2 Modifications of other parts affecting tractor performance**

Examples of such modifications are:

- changes in efficiency of the hydraulics;
- changes in gearbox design, ratios staying the same;
- changes in manufacturing some tractor components (front axle, power train, etc.).

In all these cases the station shall verify by a test the effect on tractor performance. The outcome of the PTO verification will lead to a decision in accordance with Rule 5.4.1. In order to check the other effects of the modifications, further performance verifications may be required by the station. If these tests show deviations of more than  $\pm 2.5$  per cent, the results shall be reported as repeats of compulsory or optional tests (see 1.2 above).

**ANNEX A**  
**SPECIMEN TEST REPORT**

**Note:** Units shown below, which appear in ISO 1000:1992; Amd1:1998, shall be stated and followed by national units in parentheses, if necessary.

- C**<sup>4</sup> - Tractor manufacturer's name and address:
- D** - Location of tractor assembly:
- D** - Submitted for test by:
- C** - Selected for test by:
- D** - Place of running-in:
- D** - Duration of running-in: h
- C** - Location of test:

**1. SPECIFICATIONS OF TRACTOR**

**1.1 Identification**

1.1.1 Denomination

- C** - Make of the tractor:(\*)
- C** -Model (trade name) :
- C** -Type : 2 WD or 4 WD ; rubber or steel tracks (*if applicable*); articulated 4 WD or articulated 4 WD with twin (dual) wheels (*if applicable*)  
(\* *possibly different from tractor manufacturer's name*)

1.1.2 Numbers

- D** - 1st Serial N° or prototype
- C** - Serial N°:

1.1.3 Other specification (if applicable)

- D** - Model(s) for other countries:
- C** - Transmission type or gears x ranges:
- C** - Speed version : 30 or 40 km/h

---

<sup>4</sup> The information opposite each item shall be validated by the Testing Station. An item marked "C" indicates to the test report user that the information declared by the manufacturer has been checked; an item marked "D" that the manufacturer's declaration has been endorsed. For example, the make of the supercharging device is declared by the manufacturer and checked "C" as consistent with the tractor by the testing station, while the pressure of the supercharging device is simply declared "D" by the manufacturer. Testing station's markings show compliance with article 9 of Appendix 3 to the Decision. When an item marked "C" in the specimen test report has not been checked by the testing station. The item shall be marked "D" and a foot not added giving the reasons why the testing station has not checked it.

- D - Manufacturer identification or Technical type number:
- 1.2 Engine**
  - C - Make/Model/Type:
  - C - Serial N°:
  - 1.2.1 Cylinders**
    - C - Number/disposition:
    - D - Bore/stroke: mm/mm
    - D - Capacity: cm<sup>3</sup>
    - D - Compression ratio:
    - D - Arrangement of valves:
    - D - Cylinder liners (wet or dry):
  - 1.2.2 Supercharging**
    - C - Make/Model/Type:
    - D - Pressure:MPa
  - 1.2.3 Fuel system**
    - C - Fuel feed system:
    - C - Make/Model/Type of fuel filter(s):
    - D - Capacity of fuel tank: dm<sup>3</sup>
    - C - Make/Model/Type of injection pump:
    - C - Serial N°:
    - Manufacturer's production setting of injection pump
    - C . Flow rate (rated engine speed and full load): dm<sup>3</sup>/h
    - D . Timing:
    - D - Make/Model/Type of injectors:
    - D - Injection pressure: MPa
    - C - Make/Model/Type of carburettor:
  - 1.2.4 Governor**
    - C - Make/Model/Type:
    - C - Governed range of engine speed from \_\_\_ to \_\_\_ min-1(rev/min)
    - C - Rated engine speed: min-1(rev/min)
  - 1.2.5 Air cleaner**
    - Pre-cleaner
      - C - Make/Model/Type:
      - C - Location of air intake:
    - Main cleaner
      - C - Make/Model/Type:
      - C - Location of air intake (in case of no pre-cleaner):
      - C - Maintenance indicator:

1.2.6 Lubrication system

- D - Type of feed pump:
- C - Type of filter(s):
- C - Number of filters:

1.2.7 Cooling system

- C - Type of coolant:
- D - Type of pump:
- Specification of fan or blower
  - C - Number of fan blades:
  - C - Fan diameter: mm
- D - Coolant capacity: dm<sup>3</sup>
- C - Type of temperature control:
- D - Over-pressure system: kPa

1.2.8 Starting system

- C - Make/Model/Type:
- D - Starter motor power rating: kW
- C - Cold starting aid:
- C - Safety device:

1.2.9 Electrical system

- C - Voltage: V
- Generator
  - C - Make/Model/Type:
  - D - Power: kW
- Battery of accumulators
  - C - Number:
  - D - Rating: Ah at \_\_\_ hours

1.2.10 Exhaust system

- C - Make/Model/Type:
- C - Location:

**1.3 Transmission**

1.3.1 Clutch (travel and power take-off/travel alone)

- D - Make/Model/Type:
- D - Number of plates:
- D - Diameter of plates: mm
- C - Method of operation:

1.3.2 Gear box

- D** - Make/Model/Type:  
 - Description:

		Forward	Reverse
<b>C</b>		Number of ranges/groups	
<b>C</b>		Number of gears	
<b>C</b>		Total of arrangements	

- D** - Available options:

1.3.3 Rear axle and final drives

- D** - Make/Model/Type:  
 - Differential lock  
**D** - Type:  
**C** - Method of engagement:  
**C** - Method of disengagement:

1.3.4 Front axle and final drives

- D** - Make/Model/Type:  
 - Differential lock  
**D** - Type:  
**C** - Method of engagement:  
**C** - Method of disengagement:

1.3.5 Total ratios and travelling speeds

		Gear No	Group or range	Number of engine revolutions for one revolution of the driving wheels	Nominal travelling speed (*) at rated engine speed of ___ min <sup>-1</sup> (rev/min) km/h
<b>C</b>					
<b>C</b>					
<b>C</b>					
		(*) Calculated with a tyre dynamic radius index of __. mm (pneumatic tyred tractors only) (ISO 4251-1:1998).			

- C** - Number of revolutions of front wheels for one revolution of rear-wheels (for 4WD tractors only):

**1.4 Power take-off**

1.4.1 Main power take-off

- C** - Type (independent, semi-independent or not independent):  
**C** - Method of engagement (if necessary describe the type of clutch):

- C - Number of shafts:
- C - Method of changing power take-off shaft ends and speeds:

1.4.1.1 Power take-off proportional to engine speed

Power take-off at 540 min<sup>-1</sup>(rev/min)

- C - Location:
- C - Diameter of power take-off shaft end: mm
- C - Number of splines: \_\_\_\_, in conformity/not in conformity with ISO 500:1991
- C - Height above ground: mm
- C - Distance from the median plane of the tractor: mm
- C - Distance behind rear-wheel axis: mm
- C - PTO speed at rated engine speed ( ... rev/min): min<sup>-1</sup> (rev/min)
- C - Engine speed at standard power take-off speed: min<sup>-1</sup> (rev/min)
- C - Ratio of rotation speeds (engine speed/p.t.o speed):
- D - Power restriction: kW
- D - Maximum torque transmissible: Nm
- C - Direction of rotation (viewed from behind tractor):

Power take-off at 1000 min<sup>-1</sup>(rev/min)

- C - Location:
- C - Diameter of power take-off shaft end: mm
- C - Number of splines: \_\_\_\_, in conformity/not in conformity with ISO 500:1991
- C - Height above ground: mm
- C - Distance from the median plane of the tractor: mm
- C - Distance behind rear-wheel axis: mm
- C - PTO speed at rated engine speed ( ... rev/min): min<sup>-1</sup> (rev/min)
- C - Engine speed at standard power take-off speed: min<sup>-1</sup> (rev/min)
- C - Ratio of rotation speeds (engine speed/p.t.o speed):
- D - Power restriction: kW
- D - Maximum torque transmissible: Nm
- C - Direction of rotation (viewed from behind tractor):

1.4.1.2 Power take-off proportional to ground speed

- C - Indicate 540 or 1000 min<sup>-1</sup>(rev/min):
- C - Travelling distance for one revolution of take-off shaft m
- C - Number of power take-off shaft revolutions for one revolution of (rear) driving wheels:
- C - Direction of rotation with forward gear engaged (viewed from behind tractor):

1.4.2 Optional power take-off

- C - Give the same description as for the main PTO.

**1.5 Hydraulic power lift**

- C - Make/Model/Type:
- C - Type of hydraulic system:
- C - Type and number of cylinders (single or double-acting):
- C - Type of linkage lock for transport:
- D - Relief valve pressure setting (tolerance): MPa
- D - Opening pressure of cylinder safety valve (if fitted): MPa
- D - Lift pump type:
- D - Transmission between pump and engine:
- C - Type and number of filters:
- C - Site of oil reservoir:
- C - Type, number and location of tapping points:
- D - Maximum volume of oil available to external cylinders: dm<sup>3</sup>

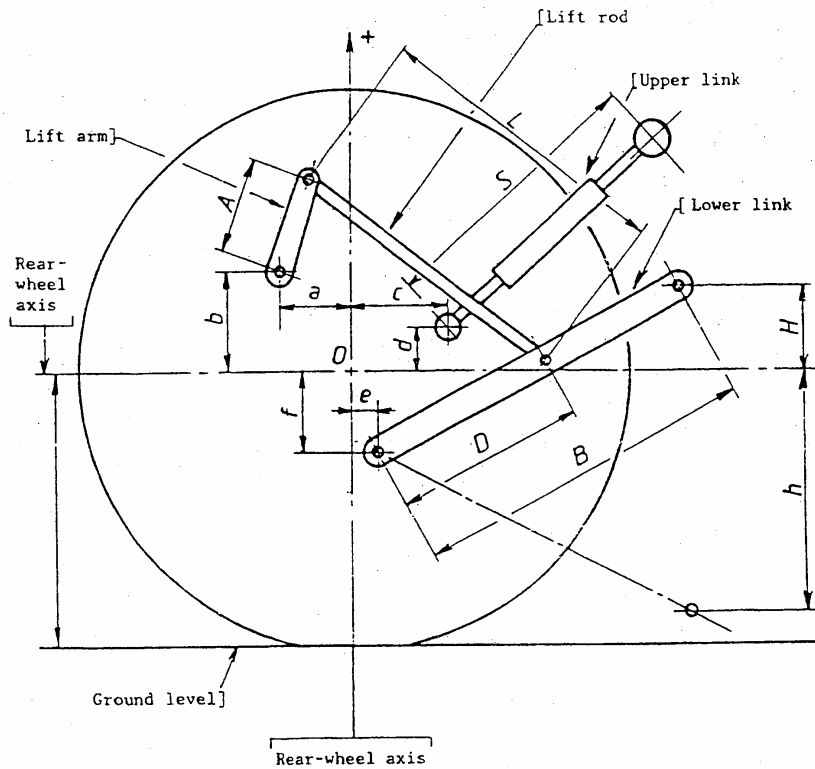

Figure 1.1

**Lift test - Linkage geometry**

Give detailed figures of power lift and complete table 1.1 (section 1.6) with values corresponding to the dimensions of the figure above

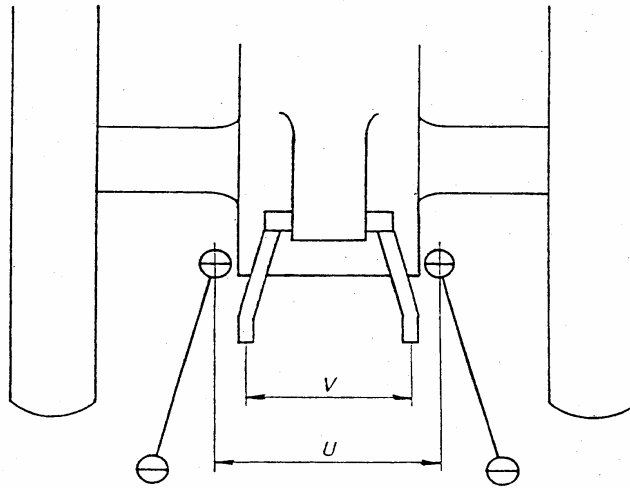

Figure 1.2

**Lift test - Linkage geometry**

Give detailed graph of power lift and complete table 1.1 (section 1.6) with values corresponding to the dimensions of the graph above

**1.6 Three point linkage**

<b>C</b>	- Category: ....., in conformity/ not in conformity with categories 1 or 2 or 3 or 4 or 1N of ISO 730-1:1994 + Cor.1:1995 and ISO 730-2:1979.
<b>C</b>	- Category adapter:

Table 1.1

**Dimensions of linkage geometry when connected to the standard frame**

		Figures 1.1 and 1.2	Dimension or range mm	Settings used in test mm
<b>C</b>	Length of lift arms:	<b>(A)</b>		
<b>C</b>	Length of lower links:	<b>(B)</b>		
	Distance of lift arm pivot point from rear-wheel axis :			
<b>C</b>	- horizontally	<b>(a)</b>		
<b>C</b>	- vertically	<b>(b)</b>		
<b>C</b>	Horizontal distance between the 2 lower link points:	<b>(u)</b>		

C	Horizontal distance between the 2 lift arm end points:	(v)		
C	Length of upper link:	(S)	from __ to __.	
	Distance of upper link pivot point from rear wheel axis :			
C	- horizontally	(c)	from __ to __.	
C	- vertically	(d)		
	Distance of lower link pivot point from rear wheel axis :			
C	- horizontally	(e)	from __ to __.	
C	- vertically	(f)		
C	Distance of lower link pivot points to lift rod pivot points on lower links:	(D)	from __ to __.	
C	Length of lift rods :	(L)	from __ to __.	
	Height of lower hitch points relative to the rear-wheel axis:			
C	- in low position	(h)	from __ to __.	
C	- in high position	(H)	from __ to __.	
C	Height above ground of lower hitch points when locked in transport position (*)		from __ to __.	

(\*) Assuming  $r = \dots\dots$  tyre dynamic radius index of ISO 4251-1:1998 (pneumatic tyred tractors only)

### 1.7 Swinging drawbar

C	- Type:	
	- Height above ground	
C	- Maximum:	mm
C	- Minimum:	mm
C	- Type of adjustment:	
C	- Distance of hitch point from rear-wheel axis, horizontally:	mm
	- Distance of hitch point from power take-off shaft end	
C	- Vertically:	mm
C	- Horizontally:	mm
	- Lateral adjustment (centre of clevis)	
C	- Right hand:	mm
C	- Left hand:	mm
C	- Distance of pivot point from rear-wheel axis, horizontally:	mm
C	- Diameter of drawbar pinhole:	mm
D	- Maximum vertical permissible load:	kN

### 1.8 Trailer hitch

C	- Type:	
C	- Hole diameter:	mm
C	- Height above ground:	mm
C	- Distance of hitch point from rear-wheel axis, horizontally:	mm
	- Distance of hitch point from power take-off shaft end	
C	- Vertically:	mm
C	- Horizontally:	mm
D	- Maximum vertical permissible load:	kN

**1.9 Holed drawbar**

- C - Number of holes:
- C - Distance between holes: mm
- C - Hole diameter: mm
- C - Thickness/width of the drawbar: mm/mm
- Height above ground
- C - Minimum: mm
- C - Maximum: mm
- C - Horizontal distance to power take-off shaft end (rear): mm

**1.10 Steering**

- D - Make/Model/Type:
- Method of operation
- D - Pump(s):
- D - Ram(s):
- D - Working pressure: MPa

**1.11 Brakes**

1.11.1 Service brake

- D - Make/Model/Type:
- C - Method of operation:
- C - Trailer braking take-off (hydraulic or air brake):

1.11.2 Parking brake

- C - Type:
- C - Method of operation:

**1.12 Wheels**

- Number
- C - Front: \_\_\_ driving /steering
- C - Rear: \_\_\_ driving /steering
- C - Wheelbase: mm
- Track width adjustment:

		Minimum mm	Maximum mm	Adjustment method
D	Front			
D	Rear			

**1.13 Protective structure**

- C - Make/Model/Type:
- C - Manufacturer's name and address:
- Protective device
- C - Cab/frame/rollguard/other:
- C - Tilttable/not tilttable:

- OECD approval
- C** - Approval number:
- C** - Date of approval:
- C** - Nos. of minor modification certificates, if any:

**1.14 Seat**

1.14.1 Driver's seat

- C** - Make/Model/Type:
- C** - Seat and steering wheel reversible: Yes/No
- C** - Type of suspension:
- C** - Type of damping:
- Range of adjustment
- C** - Longitudinally: mm
- C** - Vertically: mm
- C** - Safety belt: Yes/No
- Type :

1.14.2 Optional driver's seat(s)

- D** - Make/Model/Type:
- D** - Type of suspension:
- D** - Type of damping:
- Range of adjustment
- D** - Longitudinally: mm
- D** - Vertically: mm

1.14.3 Passenger seat

- C** - Location:
- C** - Capacity (number):

**1.15 Lighting**

		Height above ground of centre	Size	Distance from outside edge of lights to median plane of tractor
		mm	mm	mm
<b>C</b>	Headlights			
<b>C</b>	Sidelights			
<b>C</b>	Rearlights			
<b>C</b>	Reflectors			

**2. TEST CONDITIONS**

Separate tables may be added to report other test conditions or equipments.

**2.1 Overall dimensions**

	Length	Width		Height at top of	
		minimum	maximum	protective structure	exhaust pipe
	mm	mm	mm	mm	mm
Ballasted					
Unballasted					

**2.2 Ground clearance** (unballasted tractor): mm

Clearance-limiting part:

**2.3 Tractor mass**

Mass (with or without frame/ roll guard/ cab/ other):

	Ballasted		Unballasted	
	Without driver	With driver	Without driver	With driver
	kg	kg	kg	kg
Front				
Rear				
Total				

**2.4 Ballast**

	Weights		Water
	Number	Total mass	kg
		kg	
Front			
Rear			
Optional			

**2.5 Track specifications**

Track materials

Track width and base mm

Dynamic radius (rolling radius) mm

Track support system

Tread bars

Number of tread bars per metre

Height, width and length mm      mm      mm

Other specifications

**2.6 Tyres and track width specifications**

	Front	Rear
Tyres:		
- dimensions		
- ply rating		
- type		
- maximum load (tyre manufacturer's)	kN	kN
- maximum load (tractor manufacturer's)	kN	kN
- inflation pressure (tyre manufacturer's)	kPa	kPa
- dynamic radius index	mm	mm
Chosen track width	mm	mm

**2.7 Fuel**

- Type: , in conformity/not in conformity with national standard.

- Density at 15°C: g/cm<sup>3</sup>

**2.8 Oils and lubricants**

2.8.1 Capacity and change interval

	Capacity dm <sup>3</sup>	Oil change h	Filter change h
Engine			
Gear box			
Front axle			
Rear axle			
Final drive (front)			
Final drive (rear)			
Hydraulic system (*)			
Other (steering, ... )			

(\*) State if common with gear box and rear axle.

2.8.2 Specifications (SAE, API, CCMC, ACEA, Mil.L, ISO)

	Recommended	Used during test
<b>Engine oil</b> . Type: . Viscosity: . Classification:		
<b>Transmission oils</b> . Type: . Viscosity: . Classification:		
<b>Hydraulic fluid</b> . Type: . Viscosity: . Classification:		

<b>Steering oil</b> . Type: . Viscosity: . Classification:		
---	--	--

2.8.3 Grease

- Number of lubrication points:

**3. TEST RESULTS**

**3.1 Main power take-off**

- Date and location of tests:
- Type of dynamometer bench:

- Type of dynamometer bench: Power	Speed			Fuel consumption			Specific energy
	Engine	P. T.O.	Fan	Hourly		specific	
kW	min <sup>-1</sup> (rev/min)			kg/h	l/h	g/kWh	kWh/l
<b>3.1.1 MAXIMUM POWER - ONE-HOUR TEST</b>							
<b>3.1.2 POWER AT RATED ENGINE SPEED</b>							
<b>3.1.3 POWER AT STANDARD PTO SPEED [1000 ± 25 or 540 ± 10 min<sup>-1</sup>(rev/min)]</b>							
<b>3.1.4 PART LOADS</b>							
3.1.4.1 the torque corresponding to maximum power at rated engine speed							
3.1.4.2 85% of torque obtained in 3.1.4.1							
3.1.4.3 75% of torque defined in 3.1.4.2							
3.1.4.4 50 % of torque defined in 3.1.4.2							
3.1.4.5 25 % of torque defined in 3.1.4.2							
3.1.4.6 unloaded							
<b>3.1.5 PART LOADS AT STANDARD POWER TAKE-OFF SPEED [1000 ± 25 or 540 ± 10 min<sup>-1</sup>(rev/min)]</b>							
3.1.5.1 the torque corresponding to maximum power							
3.1.5.2 85 % of torque obtained in 3.1.5.1							
3.1.5.3 75 % of torque obtained in 3.1.5.2							

3.1.5.4	50 % of torque obtained in 3.1.5.2						
3.1.5.5	25 % of torque obtained in 3.1.5.2						
3.1.5.6	unloaded						

- No load maximum engine speed: min<sup>-1</sup>(rev/min)
- Torque (equivalent crankshaft) at maximum power
  - At rated engine speed Nm
  - At 1-hour test Nm
- Maximum torque (equivalent crankshaft): Nm  
 (engine speed: \_\_\_\_ min<sup>-1</sup> (rev/min))

<b>Mean atmospheric conditions:</b>	
Temperature	°C
Pressure	kPa
Relative humidity	%
<b>Maximum temperatures:</b>	
Coolant	°C
Engine oil	°C
Fuel	°C
Engine air intake	°C

3.1.6	PART LOADS AT DIFFERENT ENGINE SPEEDS						
3.1.6.1	maximum power at rated engine speed						
3.1.6.2	80 % of power obtained in 3.1.6.1 at max. speed setting						
3.1.6.3	80 % of power obtained in 3.1.6.1 with governor control set to 90 % of rated engine speed						
3.1.6.4	40 % of power obtained in 3.1.6.1 with governor control set to 90 % of rated engine speed						
3.1.6.5	60 % of power obtained in 3.1.6.1 with governor control set to 60 % of rated engine speed						
3.1.6.6	40 % of power obtained in 3.1.6.1 with governor control set to 60 % of rated engine speed						

3.1.7 OPTIONAL: Additional power take-off ratio

- Date and location of tests:
- Type of dynamometer bench:

Power	Speed			Fuel consumption			Specific energy
	Engine	P. T.O.	Fan	Hourly		specific	
kW	min <sup>-1</sup> (rev/min)			kg/h	l/h	g/kWh	kWh/l
3.1.7.1 POWER AT STANDARD ECONOMY POWER TAKE-OFF SPEED							
3.1.7.2 POWER AT RATED ENGINE SPEED							

Mean atmospheric conditions:	
Temperature	°C
Pressure	kPa
Relative humidity	%
Maximum temperatures:	
Coolant	°C
Engine oil	°C
Fuel	°C
Engine air intake	°C

3.2 Hydraulic power and lifting force

- Date of tests:

3.2.1 Hydraulic power test

3.2.1.1 Hydraulic fluid data

Hydraulic fluid type:

Viscosity index (ISO 3448:1992):

Viscosity at 65°C

mm<sup>2</sup>/s

## 3.2.1.2 Compulsory Reporting (Test Results):

	Pressure (4)	Reservoir oil Temperature °C (65 °C target)		Engine Speed	Flow rate	Power
	MPa	Min.	Max.	rev/min <sup>-1</sup>	l/min	kW
Rated Engine Speed (Manufacturers Specification)						
3.2.1.2.1 Maximum (sustained) pressure with relief valve open as measured at the coupler Pump stalled: Yes/No	(2)			Maximum Engine Speed (Record)		
3.2.1.2.2 Flow rate corresponding to a hydraulic pressure equivalent to 90 % of the actual relief valve pressure setting and corresponding hydraulic power measured at one coupler	(2)	(3)		Maximum Engine Speed (Record)		
3.2.1.2.3 Maximum available hydraulic power with flow through a single coupler pair, and corresponding flow and available coupler outlet pressure (1)	(2)	(3)		Maximum Engine Speed (Record)		
3.2.1.2.4 Maximum available hydraulic power with coupler pairs operating simultaneously (flow through two or more coupler pairs if required), and corresponding flow and available coupler outlet pressure (1)	(2)	(3)		Maximum Engine Speed (Record)		

(1) Calculated maximum power is based on only the coupler outlet pressure (pressure near coupler where oil is exiting from tractor) and does not take into account the return coupler pressure.

(2) Record pressure as measured at the outlet coupler (pressure near coupler where oil is exiting from tractor).

(3) Average test temperature.

(4) See ISO 789-10:1996 for the specific location of the pressure measurements and other referenced terms.

3.2.1.3 OPTIONAL Test Results, Supplementary Reporting :

	Pressure (4)	Reservoir oil Temperature °C (65 °C target)		Engine Speed	Flow rate	Power
	MPa	Min.	Max.	rev/min <sup>-1</sup>	l/min	kW
3.2.1.3.1 Maximum available flow and <i>maximum usable (continuous)</i> power from one coupler:	(5)	(3)		Rated Engine Speed (Record)		
3.2.1.3.2 Maximum available flow and <i>maximum usable (continuous)</i> power from coupler pairs operating simultaneously (flow through two or more coupler pairs if required):	(5)	(3)		Rated Engine Speed (Record)		
3.2.1.3.3 Maximum differential pressure Category 1 Tractor	(5)			(6)	30	
3.2.1.3.4 Maximum differential pressure Category 2 or 3 Tractor	(5)			(6)	50	
3.2.1.3.5 Peak Pressure				(6)		
3.2.1.3.6 Maximum sump return pressure with coupler				(6)		
3.2.1.3.7 Maximum return pressure without coupler				(6)		

(3) Average test temperature.

(4) See ISO 789-10:1996 for the specific location of the pressure measurements and other referenced terms.

(5) Record differential pressure (pressure near coupler where oil is exiting from tractor – pressure near coupler where oil is re-entering the tractor).

(6) Record engine speed (Maximum or rated engine speed) as requested by the manufacturer. In the case of rated engine speed tests, the throttle or governor control lever shall be adjusted to maintain the rated engine speed within the limits as specified in section 1.19. For tests at maximum engine speed, the engine speed is continuously recorded during the tests.

3.2.2 Compulsory Power lift test

- Linkage settings for test - see Table 1.1 and Figures 1.1 and 1.2.

	at the hitch point	on the frame
Height of lower hitch points above ground in down position	mm	mm
Vertical movement	mm	mm
Maximum corrected force exerted through full range	kN	kN
Corresponding pressure of hydraulic fluid	MPa	MPa
Moment about rear-wheel axis	kNm	kNm
Maximum tilt angle of mast from vertical	degrees	degrees

Lifting heights relative to the horizontal plane including the lower link pivot points									
mm	-	-	-	-	0	+	+	+	+
Lifting forces (the values of force measured shall be corrected to correspond to a hydraulic pressure equivalent to 90 % of the actual relief valve pressure setting of the hydraulic lift system):									
at the hitch points in kN:									
Corresponding pressure: _____									MPa
at the frame in kN :									
Corresponding pressure: _____									MPa

3.3 Compulsory drawbar power and fuel consumption test (unballasted tractor)

- Date of tests:
- Type of track:

Height of drawbar above ground	Tyre inflation pressure	
	Front	Rear
mm	kPa	kPa

**CODE 2 - March 2005**

Gear Number and range	Power kW	Drawbar pull kN	Speed km/h	Engine speed min <sup>-1</sup>	Fan speed min <sup>-1</sup>	Slip of wheels and/or tracks %	Specific fuel consumption g/kWh	Specific energy kWh/l	Temperature			Atmospheric conditions		
									Fuel °C	Coolant °C	Engine oil °C	Temperature °C	Relative humidity %	Pressure kPa
3.3.1	<b>MAXIMUM POWER IN TESTED GEARS/SPEED SETTINGS</b>													
3.3.2	<b>FUEL CONSUMPTION</b>													
3.3.2.1	in selected gear/speed setting nearest 7.5 km/h, at maximum power at rated engine speed													
3.3.2.1.1	75 % of pull corresponding to maximum power at rated engine speed													
3.3.2.1.2	50 % of pull corresponding to maximum power at rated engine speed													
3.3.2.1.3	highest gear/speed setting at reduced engine speed able to achieve both 3.3.2.1.1 and 3.3.2.1.2; same pull and travelling speed as in 3.3.2.1.1													
3.3.2.1.4	same gear/speed selection as 3.3.2.1.3 at reduced engine speed; same pull and travelling speed as in 3.3.2.1.2													
3.3.2.2	in selected gear/speed setting nearest between 7 km/h and 10 km/h at rated engine speed													
3.3.2.2.1	75 % of pull corresponding to maximum power at rated engine speed													
3.3.2.2.2	50 % of pull corresponding to maximum power at rated engine speed													
3.3.2.2.3	highest gear/speed setting at reduced engine speed able to achieve both 3.3.2.2.1 and 3.3.2.2.2; same pull and travelling speed as in 3.3.2.2.1													
3.3.2.2.4	same gear/speed setting as 3.3.2.2.3 at reduced engine speed; same pull and travelling speed as in 3.3.2.2.3													

3.3.3 In case of tracklaying tractors, the following table will be used: *Drawbar power test (steel-wheeled and steel-tracked tractors)*

Maximum drawbar pull	kN
Slip corresponding To 7 %	%
	kN

3.3.4 Optional additional drawbar tests for tractors without a power take-off or with a power take-off unable to transmit the full power from the engine (This test is compulsory if the engine test is not chosen)

Date of tests:  
 Rated engine speed: min<sup>-1</sup>  
 Selected gear and range:

Travel speed	Engine speed	Fan Speed	Drawbar-pull	Slip of wheels or tracks	Power	Increase in pull	Fuel consumption			Temperatures			Atmospheric conditions		
							Hourly	Specific	Fuel	Coolant	Engine oil	Temperature	Relative humidity	Pressure	
km/h	min <sup>-1</sup>	min <sup>-1</sup>	kN	%	kW	%	kg/h	g/kWh	°C	°C	°C	°C	%	kPa	
3.3.4.1 Two hour maximum drawbar power test															
3.3.4.2 Drawbar full load (lugging run) test															
3.3.4.3 Drawbar part load test at 75% of pull at rated engine speed															
3.3.4.4 Drawbar part load test at 50% of pull at rated engine speed															

**CODE 2 - March 2005**

**3.3.5 Optional drawbar power and fuel consumption test (ballasted tractor)**

- Date of tests:
- Type of track:

Height of drawbar above ground mm	Tyre inflation pressure	
	Front kPa	Rear kPa

Gear number and range	Power kW	Draw bar pull kN	Speed km/h	Engine speed min <sup>-1</sup>	Fan speed min <sup>-1</sup>	Slip of wheels and/or tracks %	Specific fuel consumption g/kWh	Specific energy kWh/l	Temperature			Atmospheric conditions		
									Fuel °C	Coolant °C	Engine oil °C	Temperature °C	Relative humidity %	Pressure kPa
<b>3.3.5.1 OPTIONAL MAXIMUM POWER IN TESTED GEARS/SPEED SETTINGS</b>														
<b>3.3.5.2 OPTIONAL FIVE-HOUR TESTS</b>														
<b>3.3.5.2.1 FIVE-HOUR TEST at 75% of the pull corresponding to maximum power at rated speed</b>														
<b>3.3.5.2.2 FIVE-HOUR TEST at pull corresponding to 15% wheelslip (<i>trackslip</i>: ≥ 7%), with additional ballast : ..... kg</b>														
<b>3.3.5.3 OPTIONAL TEN-HOUR TEST at 75% of the pull corresponding to maximum power at rated speed (steel-tracked or steel-wheeled tractors)</b>														

(\*)Those figures not quoted are irrelevant due to the additional ballast.

Oil consumption during ten hours duration of tests 3.3.3.1 and 3.3.3.2 or 3.3.4 : g/h

**4. OPTIONAL TEST RESULTS**

(to be recorded in a separate section)

**4.1 Engine test**

These tests shall be reported as in the main power take-off test.

**4.2 Performance at the belt pulley or at the pulley shaft**

These tests shall be reported as in the main power take-off test.

**4.3 Performance in a hot atmosphere**

- Date of tests:
- Limiting temperatures specified by the manufacturer

Coolant: °C

Engine oil: °C

- Special equipment fitted for the test:
- Fuel/petrol

Type:

Density at 15°C: g/cm<sup>3</sup>

Octane or cetane number:

- Engine oil

Type:

Viscosity and other specifications:

- Transmission oil

Type:

Viscosity and other specifications:

- Test results

Ambient temperature	Power loss at power take-off	Power take-off speed	Temperature		Atmospheric pressure
			Coolant	Engine oil	
°C	%	min <sup>-1</sup> (rev/min)	°C	°C	kPa

#### 4.4 Low temperature starting

- Date of tests:
- Details of the starting aids used for the tests, battery(ies) included:
- Fuel/petrol

Type:

Octane or cetane number:

Pour-point and other specifications: °C

- Engine oil

Type:

Viscosity and other specifications:

- Test results

Starting procedure used for the tests:

Lowest temperature at which the engine started: °C

#### 4.5 Turning area and turning circle

Wheel equipment if several sets of tyres are tested.

	Without brakes	
	Right-hand	Left-hand
	m	m
Radius of turning area		
Radius of turning circle		

#### 4.6 Location of centre of gravity

- Height above ground: mm
- Distance from the vertical plane containing the axis of the rear-wheels: mm
- Distance from the median longitudinal plane of the tractor: mm
- If the angle of suspension of the tractor is less than 20°, indicate its value: °

#### 4.7 Braking

- Date of tests:

##### 4.7.1 Cold service braking device test

	Speed before application of brakes	Braking device control force	Mean deceleration	Minimum stopping distance without locking the wheels
	km/h	kN	m/s <sup>2</sup>	m
Ballasted tractor				
Unballasted tractor				

- Maximum deviation of tractor from its original course:
- Abnormal vibration:

4.7.2 Fade test

	<b>Speed before application of brakes</b>	<b>Braking device control force</b>	<b>Mean deceleration</b>	<b>Minimum stopping distance without locking the wheels</b>
	km/h	kN	m/s <sup>2</sup>	m
Ballasted tractor (only)				

- Maximum deviation of tractor from its original course:
- Abnormal vibration:
- Brake heating method:

4.7.3 Parking braking device test

	<b>Uphill</b>	<b>Downhill</b>
Braking device control force	kN	kN

4.8 Measurement of external noise

- Date of tests:
- Sound level meter, make/model/type:
- Type of track:
- Gear number:
- Travelling speed before acceleration: km/h
- Sound level: dB(A)

4.9 Waterproofing test

- Date of tests:
- Water level from ground to top: mm
- Gear number:
- Test results

<b>Parts</b>	<b>Checking method</b> (describe in accordance with test procedures)	<b>Result</b> (Pass/Fail/Not Applied for)
Wheel axles		
Brake assembly		
Clutch housing		
Other parts (specify)		

- Statement

The tractor is a waterproof tractor in accordance with the Code  
Yes/No/Not Applied for

**5. REPAIRS**

**6. REMARKS**

**7. ANNEX (CURVES)**

**8. MINOR MODIFICATION CERTIFICATE**

- OECD approval number according to Code 1:
- Station test n° for the original report:
- Date and location of test:
- Date of approval:
- Modification number: MOD
- The previous Modification Certificate (MOD\_\_\_\_. ) remains / does not remain valid.

**8.1 Specification of the Tractor**

8.1.1 Manufacturer's name and address:

Submitted for test by:

8.1.2 Make of the tractor: (if different from tractor manufacturer's name)

Model (trade name):

Type: 2-WD or 4-WD rubber or steel tracks (if applicable);

articulated 4-WD or articulated 4-WD with twin (dual) wheels (if applicable)

8.1.3 Serial Number from which modification applies:

8.1.4 Other specifications (*if applicable*)

Model denomination(s) for other countries:

Transmission type or gears x ranges:

Speed versions: 30 or 40 km/h

Manufacturer identification or Technical type number:

**8.2 Details of Modifications**

Since the original test report the following modifications have been made:

---

---

**8.3 Statement**

The effect of the modifications on performance has been examined.

Modifications are considered not to affect the results of the original test.

The original test report therefore applies also to the modified tractor.

Drafted on the responsibility of the national Designated Authority by the Station which carried out the original test, this certificate is circulated to all national Designated Authorities as an annex to the original test report.

Signature:

Date:

Location:

*CODE 2 - March 2005*