

CODE 9

**OECD STANDARD CODE FOR
THE OFFICIAL TESTING OF PROTECTIVE STRUCTURES
FOR TELEHANDLERS**

TABLE OF CONTENTS

1.	DEFINITIONS	9-3
1.1	Self-propelled variable-reach all-terrain trucks:	9-3
1.2	Track	9-3
1.3	Wheelbase.....	9-3
1.4	Determination of seat reference point; seat location and adjustment for test	9-4
1.5	Clearance zone.....	9-4
1.6	Deflection-Limiting Volume (DLV)	9-6
1.7	Unballasted mass	9-6
1.8	Permissible measurement tolerances	9-6
1.9	Symbols	9-6
2.	FIELD OF APPLICATION	9-7
3.	RULES AND DIRECTIONS.....	9-7
3.1	General regulations	9-7
3.2	Falling-object protective structure (FOPS) test	9-8
3.3	Roll-over protective structure (ROPS) test.....	9-10
3.4	Conditions for acceptance.....	9-15
3.5	Extension to other truck models	9-15
3.6	Minor modifications	9-16
3.7	Labelling.....	9-16
3.8	Cold weather performance of protective structures	9-16
3.9	Seatbelt anchorage performance	9-17
	SPECIMEN TEST REPORT.....	9-39
1.	SPECIFICATION OF TEST TRUCK	9-39
2.	SPECIFICATION OF PROTECTIVE STRUCTURE.....	9-41
3.	TEST RESULTS	9-43
4.	MINOR MODIFICATION CERTIFICATE.....	9-46

CODE 9

OECD STANDARD CODE
FOR THE OFFICIAL TESTING OF PROTECTIVE STRUCTURES
FOR TELEHANDLERS

(Testing of falling-object and roll-over protective structures fitted to self-propelled variable-reach all-terrain trucks for agricultural use)

1. DEFINITIONS

1.1 *Self-propelled variable-reach all-terrain trucks:*

Counterbalanced lift trucks with one or more non-swivelling articulated arms (telescopic or non-telescopic), as defined in ISO Standard 5053: 1987, § 4.13.2.2.2, designed to handle loads and operate on natural, unimproved soils or in worked areas.

1.2 *Track*

1.2.1 Preliminary definition: median plane of the wheel

The median plane of the wheel is equidistant from the two planes containing the periphery of the rims at their outer edges.

1.2.2 Definition of track

The vertical plane through the wheel axis intersects its median plane along a straight line which meets the supporting surface at one point. If **A** and **B** are the two points thus defined for the wheels on the same axle of the truck, then the track width is the distance between points **A** and **B**. The track may be thus defined for both front and rear wheels. Where there are twin wheels, the track is the distance between two planes each being the median plane of the pairs of wheels.

1.2.3 Additional definition: median plane of the truck

Take the extreme positions of points **A** and **B** for the truck rear axle, which gives the maximum possible value for the track. The vertical plane at right angles to the line **AB** at its centre point is the median plane of the truck.

1.3 *Wheelbase*

The distance between the vertical planes passing through the two lines **AB** as defined above, one for the front wheels and one for the rear wheels.

1.4 Determination of seat reference point; seat location and adjustment for test

1.4.1 Seat reference point

1.4.1.1 The reference must be established by means of the apparatus illustrated in Figure 5.3. The apparatus consists of a seat pan board and backrest boards. The lower backrest board is jointed in the region of the ischium humps (A) and loin (B), the joint (B) being adjustable in height.

1.4.1.2 The seat reference point is defined as the point in the median longitudinal plane of the seat where the tangential plane of the lower backrest and a horizontal plane intersect. This horizontal plane cuts the lower surface of the seat pan board 150 mm in front of the above-mentioned tangent.

1.4.1.3 The apparatus is positioned on the seat. It is then loaded with a force of 550 N at a point 50 mm in front of joint (A), and the two parts of the backrest board lightly pressed tangentially against the backrest.

1.4.1.4 If it is not possible to determine definite tangents to each area of the backrest (above and below the lumbar region), the following steps must be taken:

- where a definite tangent to the lower area is not possible, the lower part of the backrest board is pressed against the backrest vertically;
- where a definite tangent to the upper area is not possible, the point (B) is fixed at a height of 230 mm above the lower surface of the seat pan board, the backrest board being perpendicular to the seat pan board. Then the two parts of the backrest board are lightly pressed against the backrest tangentially.

1.4.2 Seat position and adjustment to determine the seat reference point

1.4.2.1 Where the seat position is adjustable, the seat must be adjusted to its rear uppermost position;

1.4.2.2 where the inclination of the backrest and seat pan is adjustable, these must be adjusted so that the reference point is in its rear uppermost position;

1.4.2.3 where the seat is equipped with suspension, the latter must be blocked at mid-travel, unless this is contrary to the instructions clearly laid down by the seat manufacturer.

1.4.2.4 where the position of the seat is adjustable only lengthwise and vertically, the longitudinal axis passing through the seat reference point shall be parallel with the vertical longitudinal plane of the truck passing through the centre of the steering wheel and not more than 100 mm from that plane.

1.5 Clearance zone

1.5.1 Vertical reference plane

The clearance zone (Figures 5.15 to 5.17 and Table 5.2) is defined in relation to the vertical reference plane. The vertical reference plane, generally longitudinal to the truck and passing through the seat reference point and the centre of the steering wheel shall be assumed to move horizontally with the seat and steering wheel during loading but to remain perpendicular to the truck or the floor of the protective structure.

1.5.2 Determination of clearance zone

The clearance zone is defined as follows with the truck standing on a horizontal surface and, where applicable, the steering wheel adjusted to the mid-position for seated driving:

1.5.2.1 A horizontal plane ($A_1 B_1 B_2 A_2$) 900 mm above the seat reference point;

1.5.2.2 An inclined plane ($G_1 G_2 I_2 I_1$) perpendicular to the reference plane and including both a point 900 mm directly above the seat reference point and the rearmost point of the seat backrest;

1.5.2.3 A cylindrical surface ($A_1 A_2 I_2 I_1$) perpendicular to the reference plane, with a radius of 120 mm, tangential to the planes defined in 1.5.2.1 and 1.5.2.2 above;

1.5.2.4 A cylindrical surface ($B_1 C_1 C_2 B_2$) perpendicular to the reference plane, having a radius of 900 mm extending forward for 400 mm and tangential to the plane defined in 1.5.2.1 above at a point 150 mm forward of the seat reference point;

1.5.2.5 An inclined plane ($C_1 D_1 D_2 C_2$) perpendicular to the reference plane, joining the surface defined in 1.5.2.4 above at its forward edge and passing 40 mm from the forward external edge of the steering wheel. In case of a high steering wheel position, this plane extends forward from $B_1 B_2$ tangentially to the surface under 1.5.2.4;

1.5.2.6 A vertical plane ($D_1 E_1 E_2 D_2$) perpendicular to the reference plane 40 mm forward of the external edge of the steering wheel (see 1.5.2.5 for the case of a high steering wheel position);

1.5.2.7 A horizontal plane ($E_1 F_1 F_2 E_2$) through the seat reference point;

1.5.2.8 A surface ($G_1 F_1 G_2 F_2$), if necessary curved, from the bottom limit of the plane defined in 1.5.2.2 above, to the horizontal plane defined in 1.5.2.7, perpendicular to the reference plane, and in contact with the seat backrest throughout its length;

1.5.2.9 Vertical planes ($J_1 E_1 F_1 G_1 H_1$) and ($J_2 E_2 F_2 G_2 H_2$). These vertical planes shall extend upwards from the seat reference point for 300 mm; the distances $E_1 E_0$ and $E_2 E_0$ shall be 250 mm;

1.5.2.10 Parallel planes ($A_1 B_1 C_1 D_1 J_1 H_1 I_1$) and ($A_2 B_2 C_2 D_2 J_2 H_2 I_2$) inclined so that the upper edge of the plane on the side on which the force is applied is at least 100 mm from the vertical reference plane.

1.5.3 Trucks with a reversible driver's position

For trucks with a reversible driver's position (reversible seat and steering wheel), the zone of clearance is the envelope of the two clearance zones defined by the two different positions of the steering wheel and the seat.

1.5.4 Optional seats

1.5.4.1 In the case of trucks that could be fitted with optional seats, the envelope comprising the seat reference points of all the options offered shall be used during the tests. The protective structure shall not enter the larger clearance zone which takes account of these different seat reference points.

1.5.4.2 In the case where a new seat option is offered after the test has been performed, a determination will be made to see whether the clearance zone around the new SRP falls within the envelope previously established. If it does not, a new test must be performed.

1.6 *Deflection-Limiting Volume (DLV)*

The Deflection-Limiting Volume shall comply with ISO 3164:1995.

1.6.1 Trucks with a reversible driver's position

For trucks with a reversible driver's position (reversible seat and steering wheel), the DLV is the envelope of the two DLV defined by the two different positions of the steering wheel and the seat.

1.6.2 Optional seats

1.6.2.1 In the case of trucks that could be fitted with optional seats, the envelope comprising the SIPs of all the options offered shall be used during the tests. The protective structure shall not enter the larger DLVs which takes into account these different seat reference points.

1.6.2.2 In the case where a new seat option is offered after the test has been performed, a determination will be made to see whether the DLV around the new SIP falls within the envelope previously established. If it does not, a new test must be performed.

1.7 *Unballasted mass*

The mass of the truck without ballasting devices and without liquid ballast in the tyres. The truck shall be in running order with tanks, circuits and radiator full, protective structure with cladding and any track equipment or additional front wheel drive components required for normal use. The operator is not included.

1.8 *Permissible measurement tolerances*

Time	± 0.2 s
Distance	± 0.5 %
Force	± 1.0 %
Mass	± 0.5 %

1.9 *Symbols*

D	(mm)	Deflection of the protective structure at the point of and in line with the load application
D'	(mm)	Deflection of the protective structure for the calculated energy required
E_{IS}	(J)	Energy input to be absorbed during side loading
E_{IL1}	(J)	Energy input to be absorbed during longitudinal loading
E_{IL2}	(J)	Energy input to be absorbed in case of a second longitudinal loading
F	(N)	Static load force
F_{max}	(N)	Maximum static load force occurring during loading, with the exception of the overload
F'	(N)	Force for the calculated energy required
M	(kg)	Mass used for calculating energy and crushing forces

2. FIELD OF APPLICATION

2.1 This OECD Standard Code is applicable to self-propelled variable-reach all-terrain trucks for agricultural use.

2.2 These are trucks which meet the definitions in 1.1 and are designed to conduct the following operations, for agricultural and forestry purposes:

- to pull trailers
- to carry, pull or propel agricultural and forestry tools or machinery and, where necessary, supply power to operate them with the truck in motion or stationary.

3. RULES AND DIRECTIONS

3.1 *General regulations*

3.1.1 The protective structure may be manufactured either by the truck manufacturer or by an independent firm. In either case a test is only valid for the model of truck on which it is carried out. The protective structure must be retested for each model of truck to which it is to be fitted. However, testing stations may certify that the strength tests are also valid for truck models derived from the original model by modifications to the engine, transmission and steering and front suspension (*see below 3.5: Extension to other truck models*). On the other hand, more than one protective structure may be tested for any one model of truck.

3.1.2 The protective structure submitted for tests must be supplied already attached in the normal manner to the truck or truck chassis on which it is used. The truck chassis shall be complete including attaching brackets and other parts of the truck that may be affected by impacts and loads imposed on the protective structure.

3.1.3 A protective structure may be designed solely to protect the driver in the event of an object falling or the truck overturning. Onto this structure it may be possible to fit weather protection for the driver, of a more or less temporary nature. The driver will usually remove this in warm weather. There are protective structures however, in which the cladding is permanent and warm weather ventilation provided by windows or flaps. As the cladding may add to the strength of the structure and if removable may well be absent when an accident occurs, all parts that can be so taken away by the driver will be removed for the purpose of the test. Doors, roof hatch and windows that can be opened shall be either removed or fixed in the open position for the test, so that they do not add to the strength of the protective structure. It shall be noted whether, in this position, they would create a hazard for the driver in the event of an object falling or the truck overturning.

Throughout the remainder of these rules, reference will only be made to testing the protective structure. It must be understood that this includes cladding of a permanent nature.

A description of any temporary cladding supplied is to be included in the specifications. All glass or similar brittle material shall be removed prior to the test. Truck and protective structure components which might sustain needless damage during the test and which do not affect the strength of the protective structure or its dimensions may be removed prior to the test if the manufacturer wishes. No repairs or adjustment may be carried out during the test.

3.1.4 Any component of the truck contributing to the strength of the protective structure such as mudguards, which has been reinforced by the manufacturer, should be described and its measurements given in the test report.

3.1.5 The tests shall be carried out without the boom of the truck.

3.2 *Falling-object protective structure (FOPS) test*

3.2.1 Apparatus

3.2.1.1 Drop test object

Standard laboratory drop test object, made of steel as shown in Figure 5.1.

An optional drop test object is a sphere or ball with a maximum diameter of 400 mm.

3.2.1.2 Means of raising the standard object to the required height.

3.2.1.3 Means of releasing the standard object so that it drops without restraint.

3.2.1.4 Surface of such firmness that it is not penetrated by the machine or test bed under the loading of the drop test.

3.2.1.5 Means of determining whether the FOPS enters the DLV during the drop test. This may be either of the following:

- a DLV, placed upright, made of a material which will indicate any penetration by the FOPS; grease may be put on the lower surface of the FOPS cover to indicate such penetration;
- a dynamic instrumentation system of sufficient frequency response to indicate the relevant deflection with respect to the DLV.

3.2.2 Test conditions

3.2.2.1 DLV requirements:

The DLV and its location shall be in accordance with ISO 3164:1995. The DLV shall be fixed firmly to the same part of the machine as the operator's seat and shall remain there during the entire formal test period.

3.2.2.2 Measurement accuracy

The measurement accuracy of the deflection of the FOPS shall be $\pm 5\%$ of the maximum deflection measured.

3.2.2.3 Machine or test bed condition

3.2.2.3.1 The FOPS to be evaluated shall be attached to the truck structure as it would be attached in actual truck use. A complete truck is not required, however, the portion on which the FOPS is mounted shall be identical to the actual structure, and the vertical stiffness of a test bed shall not be less than that of an actual truck as described in 3.2.2.3.2

3.2.2.3.2 If the FOPS is mounted on a truck, all suspension systems, including pneumatic tyres, shall be set at operating levels. Variable suspensions shall be in the maximum stiffness range.

3.2.3 Procedure

The drop test procedure shall consist of the following operations, in the order listed.

3.2.3.1 Place the standard laboratory drop test object (3.2.1.1) on top of the FOPS with the small end down, at the location designated in 3.2.3.2.

3.2.3.2 The small end of the object shall be entirely within the vertical projection of the DLV, in that volume's upright position, on the FOPS top. It is intended that the drop location includes at least a portion of the vertical projection of the top plane area of the DLV.

- Case 1: Where major, upper, horizontal members of the FOPS do not enter the vertical projection of the DLV on the FOPS top.
- The drop test object shall be placed such that it is as close as possible to the centre of gravity of the upper FOPS structure (see Figure 5.2).
- Case 2: Where major, upper, horizontal members of the FOPS do enter the vertical projection of the DLV on the FOPS top.

When the covering material of all the surface areas above the DLV is of uniform thickness, the centre of the drop test object shall be in the surface of greatest area. This area is the vertical projected area of the DLV without major, upper, horizontal members. The centre of the drop test object shall be at that point, within the surface of greatest area, which has the least possible distance from the centroid of the FOPS top (see Figure 5.2).

Where other materials or a different thickness are used in different areas above the DLV, each area in turn shall be subjected to a drop test. If design features such as cutouts for windows or equipment, or variations in cover material or thickness indicate a more vulnerable location could obviously be selected within the vertical projection of the DLV, the drop location should be adjusted to that location. In addition, if cutouts in the FOPS cover are intended to be filled with devices or equipment to provide adequate protection, those devices or equipment shall be in place during the drop test.

3.2.3.3 Raise the drop test object vertically to a height above the position indicated in 3.2.3.1 and 3.2.3.2 to develop an energy of 5800 J or 11 600 J. Two energy levels are given. The energy level shall be chosen by the manufacturer according to the intended use of the machine.

3.2.3.4 Release the drop object so that it falls without restraint onto the FOPS.

3.2.3.5 As it is unlikely that the free fall will result in the drop test object hitting at the location as specified in 3.2.3.1 and 3.2.3.2, the following limits are placed on deviations.

3.2.3.6 The initial impact of the small end of the drop test object shall be entirely within a circle of 200mm radius (the centre of this circle is to coincide with the vertical centre line of the drop test object as positioned according to 3.2.3.1 and 3.2.3.2).

3.2.3.7 The first contact between the test object and the FOPS shall only be along the small end and/or the radius contiguous to that end (see Figure 5.1).

3.2.3.8 There is no limitation on location or attitude of subsequent impacts due to rebound.

3.2.4 Performance requirements

The DLV shall not be entered by any part of the protective structure under the first or subsequent impact of the drop test object. Should the drop test object penetrate the FOPS, it shall be considered to have failed that test.

The FOPS shall completely cover and overlap the vertical projection of the DLV.

Should the same structure be used for both evaluations, the drop test procedure shall precede the loading of the structure; the removal of impact dents or replacement of the FOPS cover is permitted.

3.3 *Roll-over protective structure (ROPS) test*

3.3.1 Apparatus

To verify that the zone of clearance has not been entered during the test, a device shall be used as described in point 1.5, Figures 5.15 to 5.19 and Table 5.2.

3.3.1.1 Horizontal loading tests (Figures 5.4 to 5.9)

The following shall be used in horizontal loading tests:

3.3.1.1.1 material, equipment and means of attachment to ensure that the truck chassis is firmly fixed to the ground and supported independently of the tyres;

3.3.1.1.2 device for applying a horizontal force to the protective structure; provision shall be made so that the load can be uniformly distributed and normal to the direction of loading;

3.3.1.1.3 a beam of length not less than 250 mm nor more than 700 mm in exact multiples of 50 mm between these lengths shall be used. The beam shall have a vertical dimension of 150 mm;

3.3.1.1.4 the edges of the beam in contact with the protective structure shall be curved with a maximum radius of 50 mm;

3.3.1.1.5 universal joints or the equivalent shall be incorporated to ensure that the loading device does not constrain the protective structure in rotation or translation in any direction other than the direction of loading;

3.3.1.1.6 where the straight line defined by the appropriate beam on the protective structure is not normal to the direction of application of load, the space shall be packed so as to distribute the load over the full length;

3.3.1.1.7 equipment for measuring force and deflection in the load direction, relative to the truck chassis. To ensure accuracy, measurements shall be taken as continuous readings. The measuring devices shall be located so as to record the force and deflection at the point of and along the line of loading.

3.3.1.2 Crushing tests (Figures 5.10 to 5.14)

The following shall be used in crushing tests:

3.3.1.2.1 material, equipment and means of attachment to ensure that the truck chassis is firmly fixed to the ground and supported independently of the tyres;

3.3.1.2.2 device for applying a downward force to the protective structure, including a stiff beam with a width of 250 mm;

3.3.1.2.3 equipment for measuring the total vertical force applied.

3.3.2 Test conditions

3.3.2.1 The protective structure shall conform to production specifications and shall be fitted to the appropriate truck model chassis in accordance with the manufacturer's declared method of attachment.

3.3.2.2 The assembly shall be secured to the bedplate so that the members connecting the assembly and the bedplate do not deflect significantly in relation to the protective structure under load. The assembly shall not receive any support under load other than that due to the initial attachment.

3.3.2.3 An adjustable track width setting for the wheels, if present, shall be chosen such that no interference exists with the protective structure during the tests.

3.3.2.4 The protective structure shall be instrumented with the necessary equipment to obtain the required force-deflection data.

3.3.2.5 All tests shall be performed on the same protective structure. No repairs or straightening of any members shall be carried out between any parts of the test.

3.3.2.6 On completion of all tests, permanent deflections of the protective structure shall be measured and recorded.

3.3.3 Sequence of tests

Tests shall be conducted in the following sequence:

3.3.3.1 Longitudinal loading

For a wheeled truck with at least 50 per cent of its mass on the rear axle and for track laying trucks, the longitudinal loading shall be applied from the rear. For other trucks the longitudinal loading shall be applied from the front.

3.3.3.2 First crushing test

The first crushing test shall be applied at the same end of the protective structure as the longitudinal loading.

3.3.3.3 Loading from the side

In the case of an offset seat or non-symmetrical strength of the protective structure, the side loading shall be on the side most likely to lead to infringement of the clearance zone.

3.3.3.4 Second crushing test

The second crushing test shall be applied at the end of the protective structure opposite from that receiving the first longitudinal loading. In the case of two-post designs, the second crush may be at the same point as the first crush.

3.3.3.5 Second longitudinal loading

3.3.3.5.1 A second longitudinal loading shall be applied to trucks fitted with a tiltable (e.g. non-two post) protective structure if the structure is designed to tilt for service, unless the tilt mechanism is independent from the structural integrity of the roll-over protective structure.

3.3.3.5.2 For folding protective structures, if the first longitudinal loading was applied in the folding direction then a second longitudinal loading is not required.

3.3.3.6 Horizontal loading tests from the rear, front and side

3.3.3.6.1 General provisions

3.3.3.6.1.1 The load applied to the protective structure shall be distributed uniformly by means of a stiff beam, normal to the direction of load application (see 3.3.1.2). The stiff beam may be equipped with a means of preventing its sideways displacement. The rate of load application shall be such that it can be considered static. As the load is applied, force and deflection shall be recorded as a continuous record to ensure accuracy. Once the initial application has commenced, the load shall not be reduced until the test has been completed. The direction of the applied force shall be within the following limits:

- at start of test (no load): $\pm 2^\circ$;
- during test (under load): 10° above and 20° below the horizontal.
- The rate of load application shall be considered static if the rate of deflection under loading is not greater than 5 mm/s.

3.3.3.6.1.2 If no structural cross member exists at the point of load application, a substitute test beam which does not add strength will be utilised.

3.3.3.6.2 Longitudinal loading (Figures 5.4 to 5.6)

The load shall be applied horizontally and parallel to the median plane of the truck. If the load is applied from the rear (section 3.3.3.1), the longitudinal load and the lateral load shall be applied on different sides of the vertical reference plane. If the longitudinal load is applied from the front, it shall be on the same side as the side load.

The load shall be applied to the uppermost transverse structural member of the protective structure (i.e. that part which would be likely to strike the ground first in an overturn).

The point of application of the load shall be located at one sixth of the width of the top of the protective structure inwards from the outside corner. The width of the protective structure shall be taken as the distance between two lines parallel to the median plane of the truck touching the outside extremities of the protective structure in the horizontal plane touching the top of the uppermost transverse structural members.

The length of the load distribution device (see 3.3.1.1.2) shall be not less than one third of the width of the protective structure and not more than 49 mm greater than this minimum.

The longitudinal loading shall be stopped when:

3.3.3.6.2.1 the energy absorbed by the protective structure is equal to or greater than the required energy input, E_{IL1} where:

$$E_{IL1} = 1.4 M$$

3.3.3.6.2.2 the protective structure infringes on the clearance zone or leaves the clearance zone unprotected (performance requirement in 3.3.4 below).

3.3.3.6.3 Side loading (Figures 5.7 to 5.9)

The side load shall be applied horizontally at 90° to the median plane of the truck. It shall be applied to the upper extremity of the protective structure at a point 300 mm forward of the seat reference point.

For trucks with a reversible driver's position (reversible seat and steering wheel), it shall be applied to the upper extremity of the protective structure at the mid-point between the two seat reference points.

If it is certain that any particular part of the protective structure side will touch the ground first when the truck overturns sideways, the loading shall be applied at that point, provided that this permits uniform distribution of the load as specified in 3.3.3.6.1.1. In the case of a two-post protective structure, side loading shall be applied at the structural member uppermost on the side, regardless of the seat reference point position.

The side loading shall be stopped when:

3.3.3.6.3.1 The energy absorbed by the protective structure is equal to or greater than the required energy, E_{IS} , where:

$$E_{IS} = 1.75 M$$

3.3.3.6.3.2 The protective structure infringes on the clearance zone or leaves the clearance zone unprotected (performance requirement in 3.3.4 below).

3.3.3.7 Crushing tests (Figures 5.10 to 5.14)

3.3.3.7.1 Crushing at the rear (Figures 5.10 to 5.12)

3.3.3.7.1.1 The crushing beam shall be positioned across the rear uppermost structural members so that the resultant of the crushing forces is located in the vertical reference plane. The crushing force F shall be applied where:

$$F = 20 M$$

This force shall be maintained for five seconds after cessation of any visually detectable movement of the protective structure.

3.3.3.7.1.2 Where the rear part of the protective structure roof will not sustain the full crushing force, the force shall be applied until the roof is deflected to coincide with the plane joining the upper part of the protective structure with that part of the rear of the truck capable of supporting the truck when overturned. The force shall then be removed and the crushing beam repositioned over that part of the protective structure that would support the truck when completely overturned. The crushing force $F = 20 M$ shall then be applied.

3.3.3.7.2 Crushing at the front (Figures 5.10 to 5.12)

3.3.3.7.2.1 The crushing beam shall be positioned across the front uppermost structural members so that the resultant of the crushing forces is located in the vertical reference plane. The crushing force F shall be applied where:

$$F = 20 M.$$

This force shall be maintained for 5 seconds after cessation of any visually detectable movement of the protective structure.

3.3.3.7.2.2 Where the front part of the roof of the protective structure will not sustain the full crushing force (Figures 5.13 to 14), the force shall be applied until the roof is deflected to coincide with the plane joining the upper part of the protective structure with that part of the front of the truck capable of supporting the truck when overturned. The force shall then be removed and the crushing beam repositioned over that part of the protective structure that would support the truck when completely overturned. The crushing force $F = 20 M$ shall then be applied.

3.3.3.8 Second longitudinal loading test (Figures 5.4 to 5.6)

The load shall be applied in the opposite direction to and at the corner farthest from the point of application of the first longitudinal load.

The longitudinal loading shall be stopped when:

3.3.3.8.1 The energy absorbed by the protective structure is equal to or greater than the required energy, E_{IL2} , where:

$$E_{IL2} = 0.5 M$$

3.3.3.8.2 The protective structure infringes on the clearance zone or leaves the clearance zone unprotected (performance requirement in 3.3.4 below).

3.3.4 Performance requirements:

The protective structure shall fulfil the following conditions during and after completion of the tests:

3.3.4.1 no part shall enter the clearance zone during any part of the tests. No part may strike the seat during the tests. Furthermore, the clearance zone shall not be outside the protection of the protective structure. For this purpose, it shall be considered to be outside the protection of the structure if any part of it would come in contact with flat ground if the truck overturned towards the direction from which the test load is applied. In order to estimate this, the tyres and track width setting shall be the smallest standard fitting specified by the manufacturer;

3.3.4.2 for the articulated trucks, the median planes of the two parts shall be assumed to be in line;

3.3.4.3 after the final crushing test the permanent deflection of the protective structure shall be recorded. For this purpose, before the start of the test, the position of the main protective structure members in relation to the seat reference point must be recorded. Then any displacement of the members resulting from the loading tests and any change of the height of the front and back members of the roof of the protective structure will be recorded;

3.3.4.4 at the point where the required energy absorption is met in each of the specified horizontal loading tests the force shall exceed $0.8 F_{\max}$;

3.3.4.5 an overload test shall be required if the applied force decreases by more than 3 per cent over the last 5 per cent of the deflection attained when the energy required is absorbed by the structure (Figures 5.20 to 5.22). Description of the overload test:

3.3.4.5.1 an overload test shall consist of continuing the horizontal loading in increments of 5 per cent of the original required energy, up to a maximum of 20 per cent additional energy;

3.3.4.5.2 the overload test shall be successfully completed if after the absorption of 5, 10 or 15 per cent additional energy the force drops by less than 3 per cent for each 5 per cent increment whilst remaining greater than $0.8 F_{\max}$ or if, after the absorption of 20 per cent additional energy the force is greater than $0.8 F_{\max}$;

3.3.4.5.3 additional cracks or tears or entry into or lack of protection of the clearance zone, due to elastic deformation, are permitted during the overload test. After removing the load, however, the protective structure shall not infringe on the clearance zone, which shall be completely protected;

3.3.4.6 the required force must be sustained in both crushing tests;

3.3.4.7 there shall be no protruding member or component which would be likely to cause serious injury during an overturning accident or which, through the deformation occurring, might trap the operator, for example by the leg or foot;

3.3.4.8 there shall be no other components presenting a serious hazard to the operator.

3.4 *Conditions for acceptance*

For the structure to be accepted, it shall meet the performance requirements set out in 3.2.4 and 3.3.4.

3.5 *Extension to other truck models*

For a protective structure which has fulfilled the acceptance conditions and which is designed to be used on other models of trucks, the impact and crushing tests need not be carried out on each model of truck, provided that the protective structure and truck comply with the conditions referred to in 3.5.1 to 3.5.6 hereunder.

3.5.1 The station which performed the original test will be the only station to be allowed to request an extension of approval if required by the manufacturer;

3.5.2 The required energy shall not exceed the energy calculated for the original test by more than 5 per cent. The 5 per cent limit shall also apply to extensions in the case of substituting tracks for wheels on the same truck;

3.5.3 The method of attachment and the truck components to which the attachment is made shall be identical or of equivalent strength;

3.5.4 Any components such as mudguards and bonnet that may provide support for the protective structure shall be identical or judged to give at least the same support;

3.5.5 The position and critical dimensions of the seat in the protective structure and the relative position of the protective structure on the truck shall be such that the DLV would have remained within the protection of the deflected structure throughout FOPS test and clearance zone would have remained within the protection of the deflected structure throughout ROPS test;

3.5.6 The test report shall contain a reference to the original test report.

3.6 *Minor modifications*

If there are minor modifications on the truck such as changes of vehicle colour, decals, make or model denominations for marketing purposes, or on the protective structure like design of non-structural sheet metal parts, the testing station that has carried out the original test can issue a "Minor Modification Certificate" on the national Designated Authority's responsibility, stating all changes and confirming that the results of the strength test are not affected. No test is necessary. This certificate shall be drafted according to the specimen provided for in the Code, as an annex to the original test report and subject to the same circulation requirements.

3.7 *Labelling*

3.7.1 OECD labelling is optional. If it is utilised, it shall contain at least the following information:

3.7.1.1 the protective structure's manufacturer's name and address;

3.7.1.2 protective structure's identification number (design or serial number);

3.7.1.3 truck make, model(s) or series number(s) that the protective structure is designed to fit;

3.7.1.4 OECD approval number of protective structure.

3.7.2 The label shall be durable and permanently attached to the protective structure such that it can be easily read and it shall be protected from environmental damage.

3.8 *Cold weather performance of protective structures*

3.8.1 If the protective structure is claimed to have properties resistant to cold weather embrittlement, the manufacturer shall include these details in the report.

3.8.2 The following requirements and procedures are intended to provide strength and resistance to brittle fracture at reduced temperatures. It is suggested that the following minimum material requirements shall be met in order to judge the protective structure's suitability at reduced operating temperatures in countries requiring this additional operating protection:

3.8.2.1 Bolts and nuts used to attach the protective structure to the truck and used to connect structural parts of the protective structure shall exhibit suitable controlled reduced temperature toughness properties.

3.8.2.2 All welding electrodes used in the fabrication of structural members and mounts shall be compatible with the protective structure material as given in 3.8.2.3 below.

3.8.2.3 Steel materials for structural members of the protective structure shall be of controlled toughness material exhibiting minimum Charpy V-Notch impact energy requirements as shown in Table 5.1. Steel grade and quality shall be specified in accordance with ISO 630:1995.

Steel with an as-rolled thickness less than 2.5 mm and with a carbon content less than 0.2 per cent is considered to meet this requirement.

Structural members of the protective structure made from materials other than steel shall have equivalent low temperature impact resistance.

3.8.2.4 When testing the Charpy V-Notch impact energy requirements, the specimen size shall be no less than the largest of the sizes stated in Table 5.1 that the material will permit.

3.8.2.5 The Charpy V-Notch tests shall be made in accordance with the procedure in ASTM A 370-1979, except for specimen sizes that shall be in accordance with the dimensions given in Table 5.1.

3.8.2.6 Alternatives to this procedure are the use of killed or semi-killed steel for which an adequate specification shall be provided. Steel grade and quality shall be specified in accordance with ISO 630:1995.

3.8.2.7 Specimens are to be longitudinal and taken from flat stock, tubular or structural sections before being formed or welded for use in the protective structure. Specimens from tubular or structural sections are to be taken from the middle of the side of the greatest dimension and shall not include welds.

3.9 *Seatbelt anchorage performance (optional)*

3.9.1 Scope

Seat belts are one of the operator restraint systems used for securing the driver in motor vehicles.

This recommended procedure provides minimum performance and tests requirements for seat belt anchorage for agricultural and forestry trucks.

It applies to the anchorage of pelvic restraint systems.

3.9.2 Explanation of terms used in the performance testing

3.9.2.1 The *seat belt assembly* is any strap or belt device fastened across the lap or pelvic girdle area designed to secure a person in a machine.

3.9.2.2 The *extension belt* is intended as any strap, belt, or similar device that aids in the transfer of seat belt loads.

3.9.2.3 The *anchorage* is intended as the point where the seat belt assembly is mechanically attached to the seat system or truck.

3.9.2.4 The *seat mounting* is intended as all intermediary fittings (such as slides, etc.) used to secure the seat to the appropriate part of the truck.

3.9.2.5 The *Operator Restraint System* is intended as the total system composed of seat belt assembly, seat system, anchorages and extension which transfers the seat belt load to the truck.

3.9.2.6 *Applicable Seat Components* comprise all components of the seat whose mass could contribute to loading of the seat mounting (to the vehicle structure) during a roll-over event.

3.9.3 Test procedure

Only static tests for anchorages are given in this procedure.

The seat shall be in position during the tests and fixed to the mounting point on the truck using all intermediary fittings (such as suspension, slides, etc.) specified for the complete truck. No additional non-standard fittings contributing to the strength of the construction may be used.

The anchorages shall be capable of withstanding the loads applied to the seat belt system using a device as shown in Figure 5.23. The seat belt anchorages shall be capable of these test loads applied with the seat in the mid-position of longitudinal adjustment and at one other adjustment position, if such a position is considered by the test station to be the worst case, to ensure that the test condition is met. For a suspended seat, the seat shall be set to the midpoint of the suspension travel, unless this is contradictory to a clearly stated instruction by the seat manufacturer. Where special instructions exist for the seat setting, these shall be observed and specified in the report.

After the load is applied to the seat system, the load application device shall not be repositioned to compensate for any changes that may occur to the load application angle.

3.9.3.1 Forward loading

A tensile force shall be applied in a forward and upward direction at an angle of $45^\circ \pm 2^\circ$ to the horizontal, as shown in Figure 5.24. The seat belt anchorages shall be capable of withstanding a force of 4 450 N. In the event that the force applied to the seat belt assembly is transferred to the vehicle chassis by means of the seat, the seat mounting shall be capable of withstanding this force plus an additional force equal to four times the force of gravity on the mass of all applicable seat components, applied $45^\circ \pm 2^\circ$ to the horizontal in a forward and upward direction, as shown in Figure 5.24.

3.9.3.2 Rearward loading

A tensile force shall be applied in a rearward and upward direction at an angle of $45^\circ \pm 2^\circ$ to the horizontal, as shown in Figure 5.25. The seat belt anchorages shall be capable of withstanding a force of 2 225 N. In the event that the force applied to the seat belt assembly is transferred to the vehicle chassis by means of the seat, the seat mounting shall be capable of withstanding this force plus an additional force equal to two times the force of gravity on the mass of all applicable seat components, applied $45^\circ \pm 2^\circ$ to the horizontal in a rearward and upward direction, as shown in Figure 5.25.

Both tensile forces shall be equally divided between the seat belt anchorages.

3.9.4 Test result

Condition of acceptance

Permanent deformation of any system component and anchorage area is acceptable under the action of the forces specified in 3.9.3.1 & 3.9.3.2. However, there shall be no failure allowing release of the seat belt system, seat assembly, or the seat adjustment locking mechanism.

The seat belt buckle shall open with a maximum force of 140 N following the load applications.

The seat adjuster or locking device need not be operable after application of the test load.

Specimen size	Absorbed energy at – 30°C	Absorbed energy at – 20°C
mm	J	J
10 x 10	11.0	27,5
10 x 7.5	9.5	24
10 x 5	7.5	19
10 x 2.5	5.5	14

Minimum Charpy V-Notch impact energy requirements for protective structure material at specified temperature

Table 5.1
Impact Energy

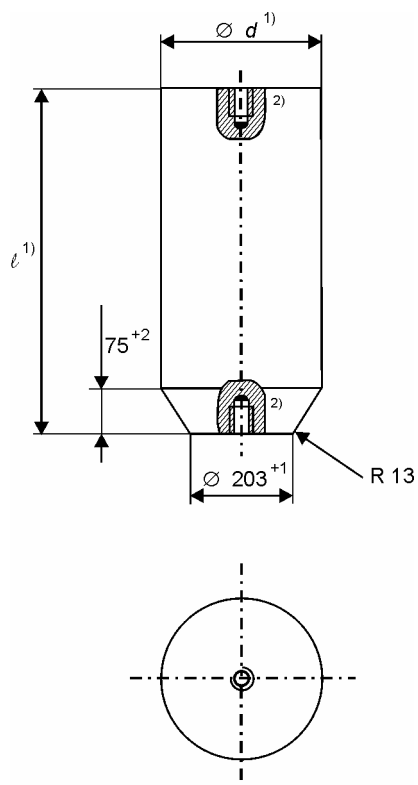

1) Dimensions d and e are optional, depending on the mass of the test object required to match the height of drop that will provide the energy specified in 3.2.3.3

For example, for a drop test object mass of 227 kg:

$d = 255$ to 260 mm

$e = 583$ to 585 mm

2) May be drilled and tapped for a lifting eye.

Figure 5.1

Standard laboratory drop test object

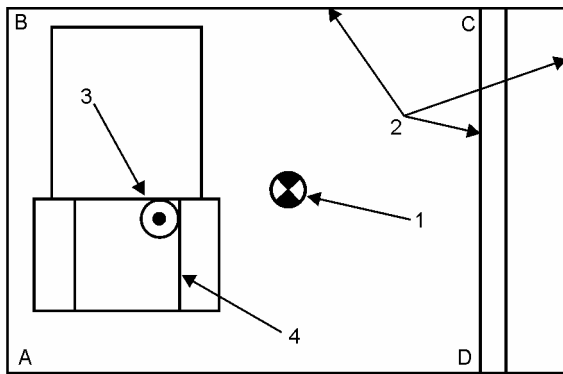

Case 1

<p>Key</p> <ol style="list-style-type: none"> 1. Centroid of A-B-C-D 2. Major members 3. Drop object 4. DLV top plane
--

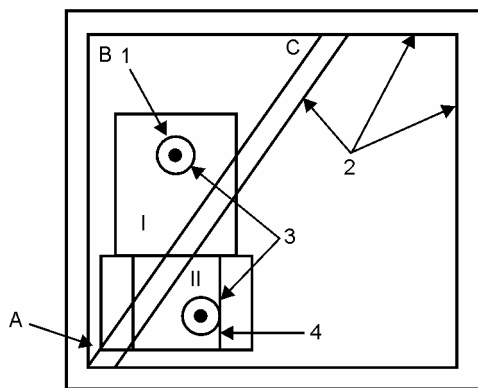

Case 2

<p>Key</p> <ol style="list-style-type: none"> 1. Centroid of A-B-C-D 2. Major members 3. Drop object 4. DLV top plane <p>Note: I has a greater area than II</p>
--

Figure 5.2
Drop test impact points

Dimensions in mm

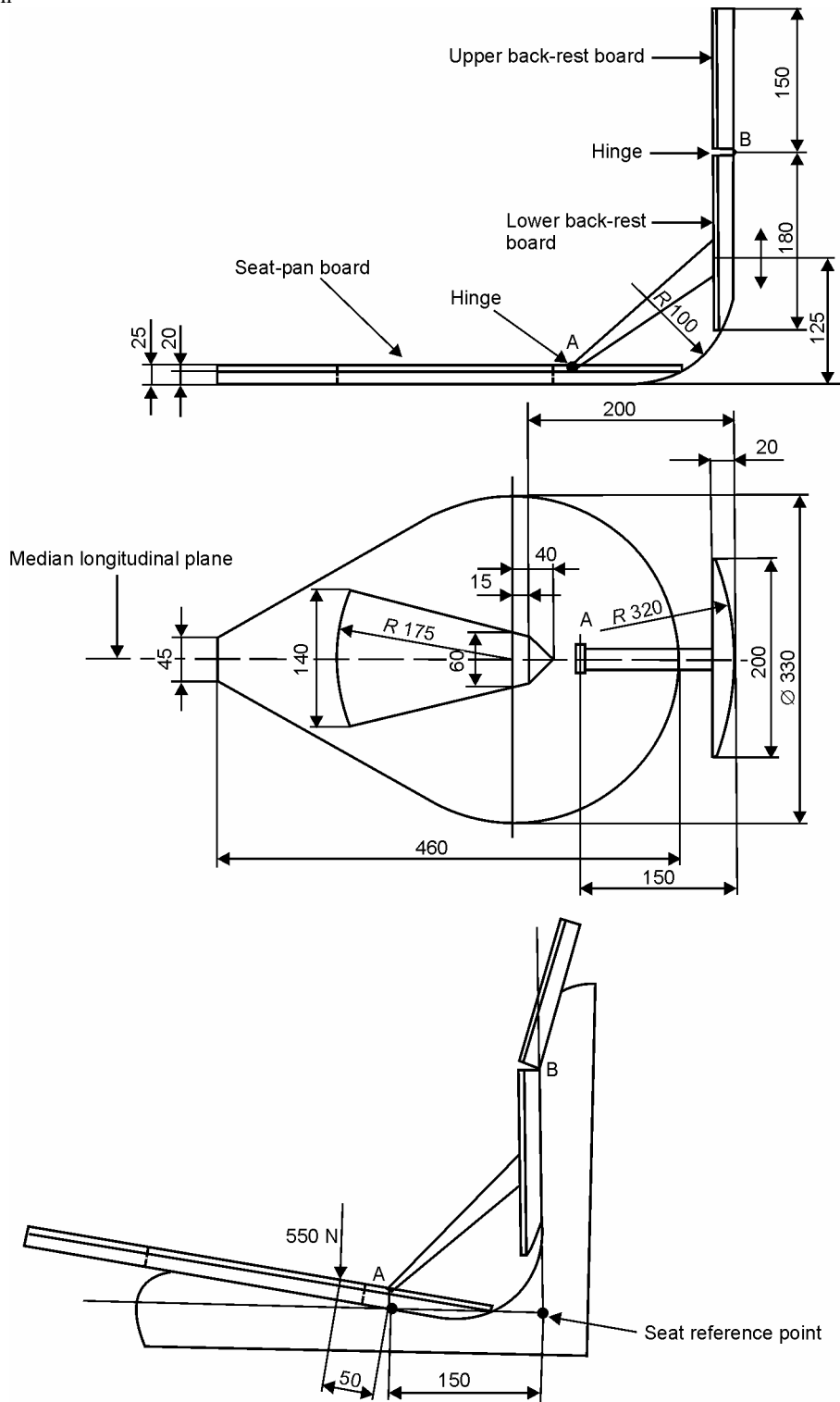

Figure 5.3

Apparatus for determination of seat reference point

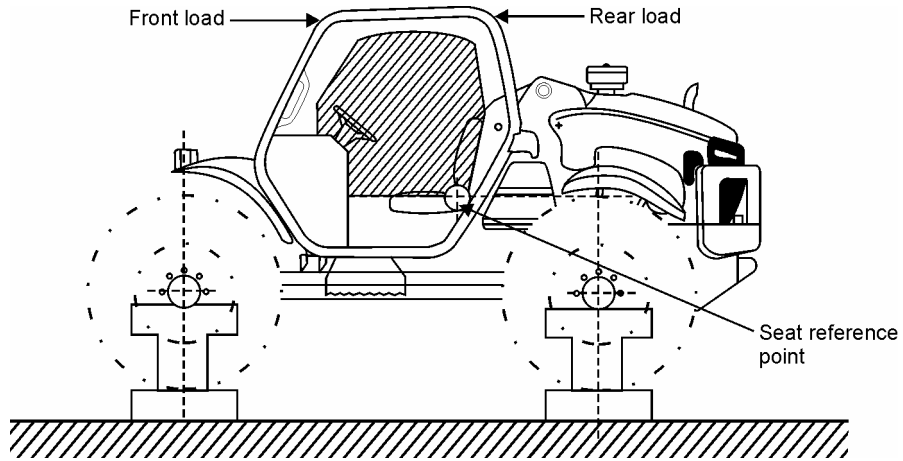

Figure 5.4
Protective cab

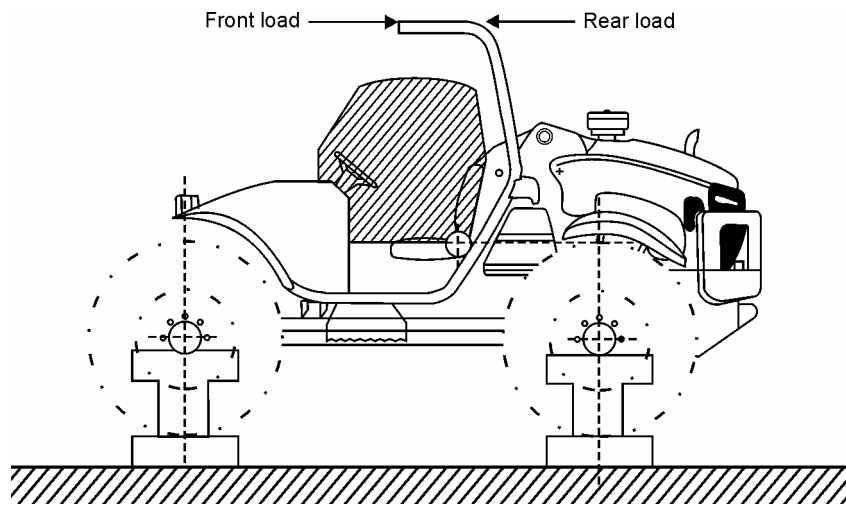

Figure 5.5
Rear roll bar frame

Front and rear load applications, protective cab and rear roll bar frame

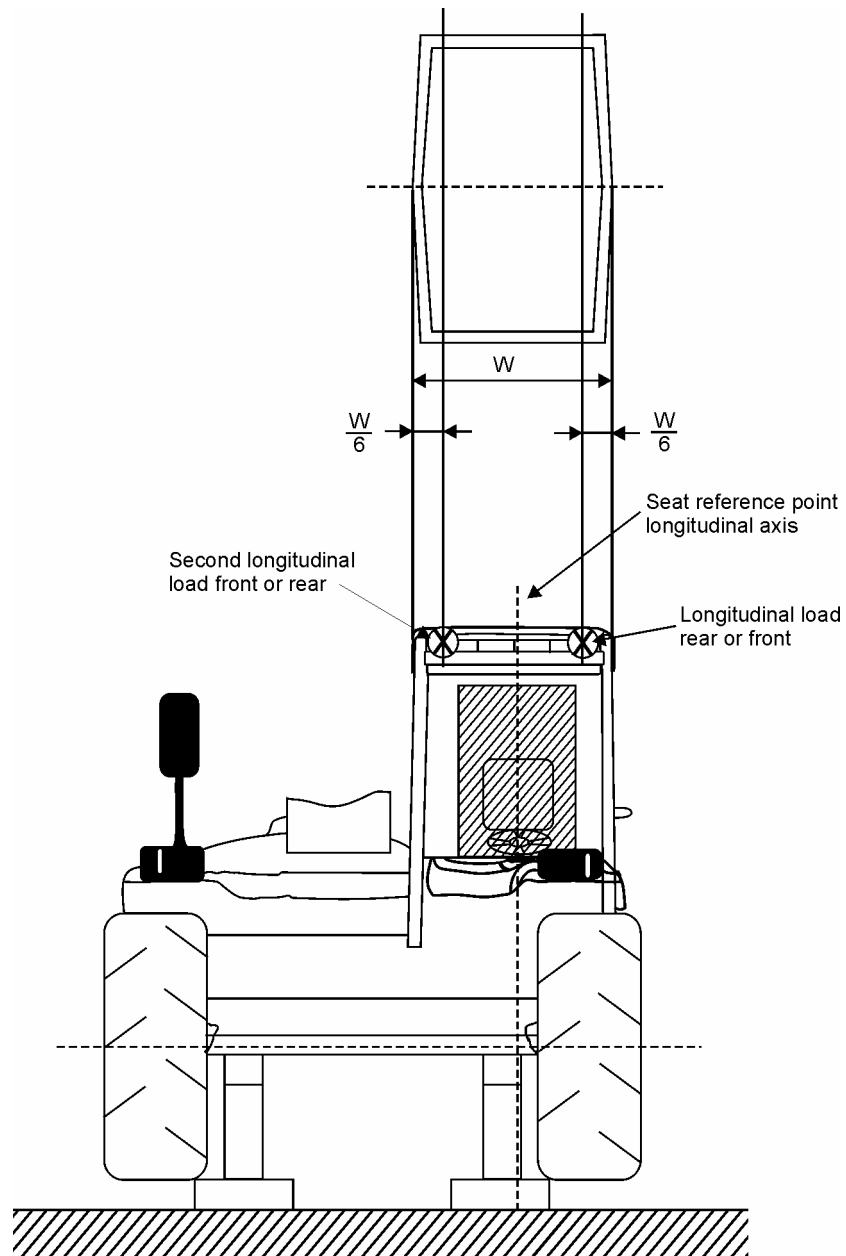

Figure 5.6
Longitudinal load applications

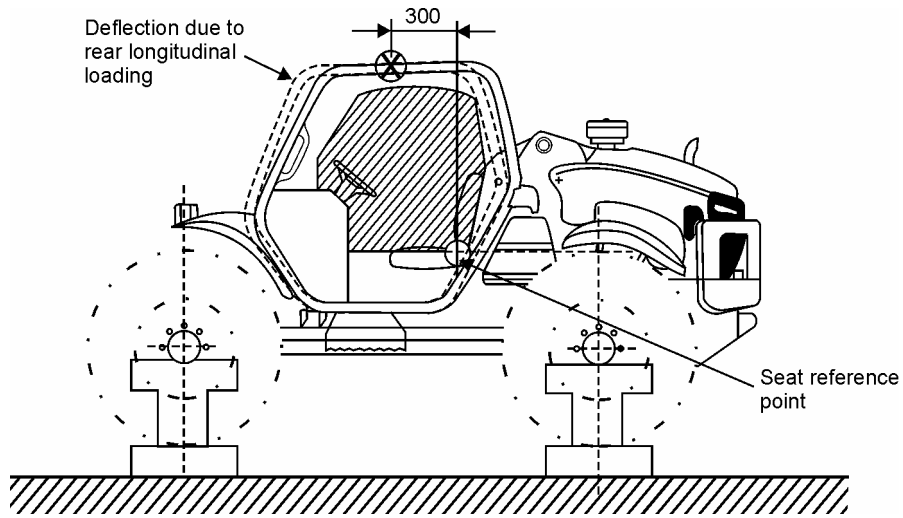

Figure 5.7
Protective cab

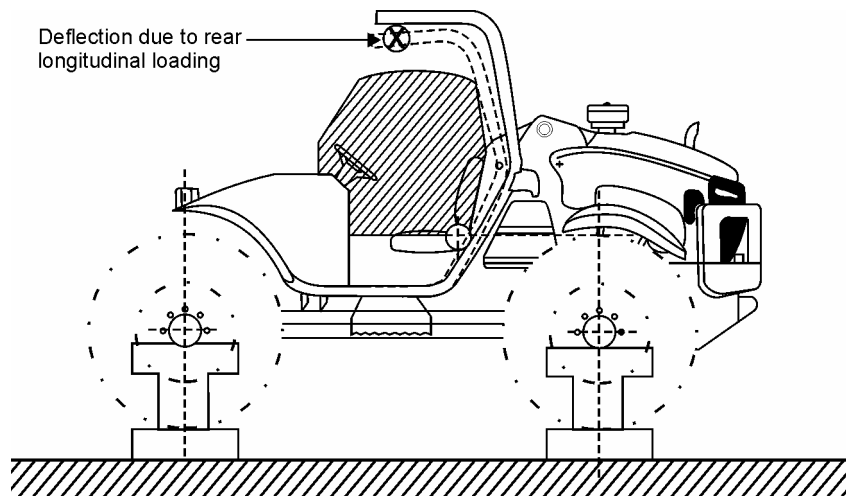

Figure 5.8
Rear roll bar frame

Side load application (side view), protective cab and rear roll bar frame

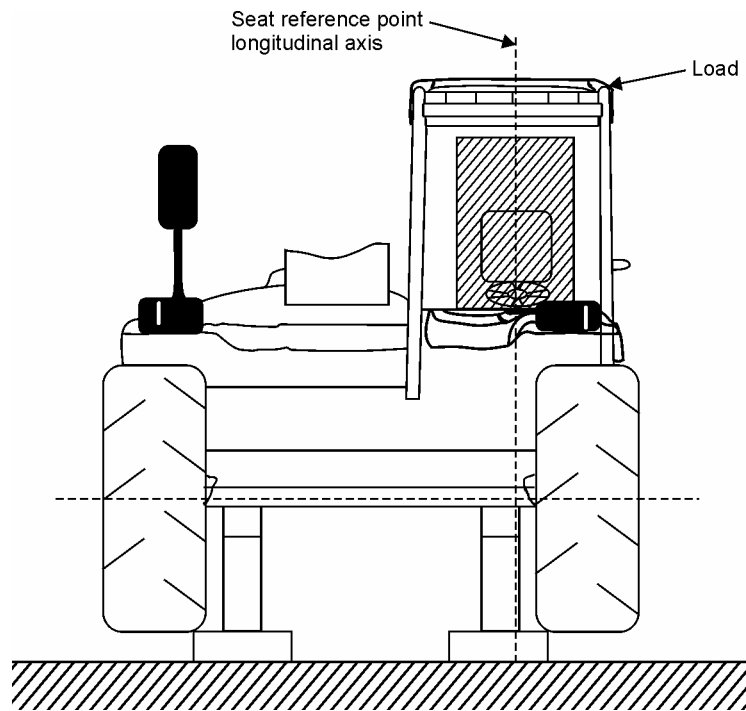

Figure 5.9
Side load application (front view)

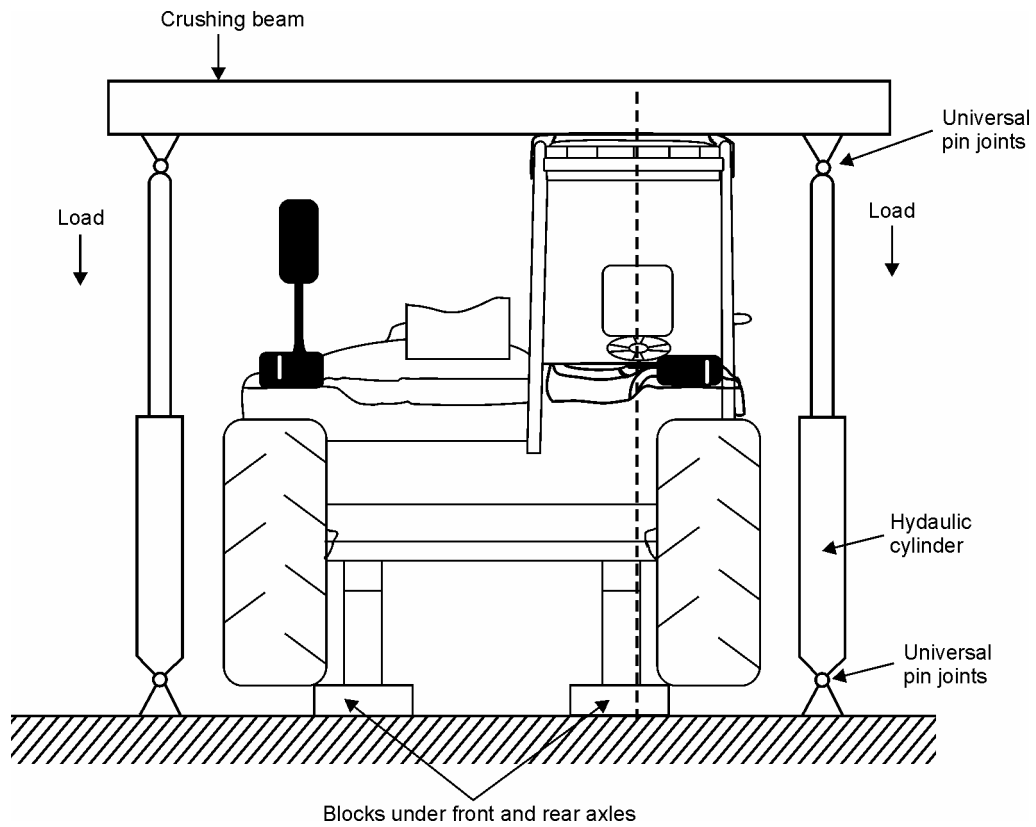

Figure 5.10
Example of an arrangement for crushing test

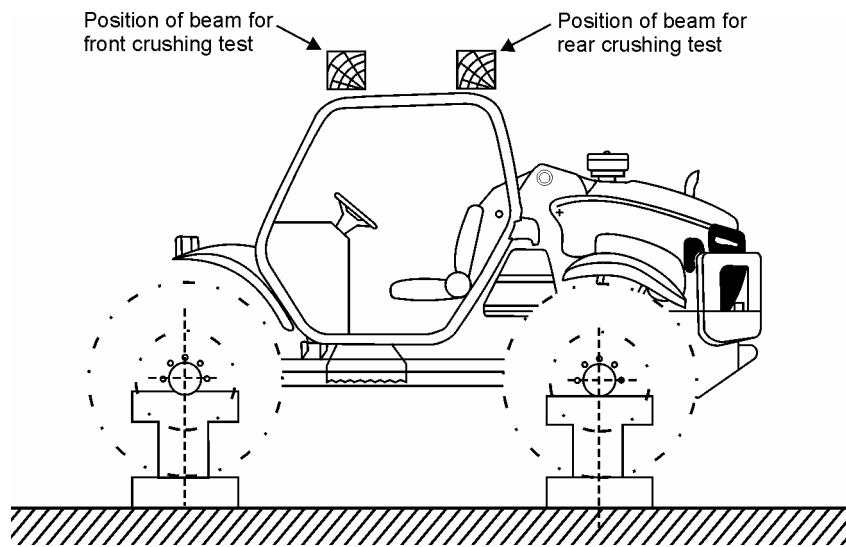

Figure 5.11
Protective cab

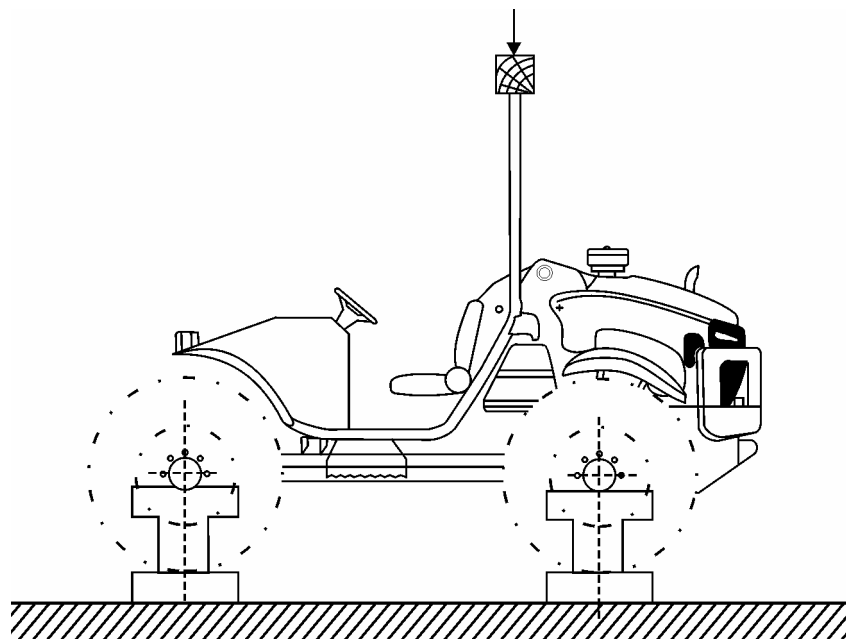

Figure 5.12
Rear roll bar frame

Position of beam for front and rear crushing tests, protective cab and rear roll bar frame

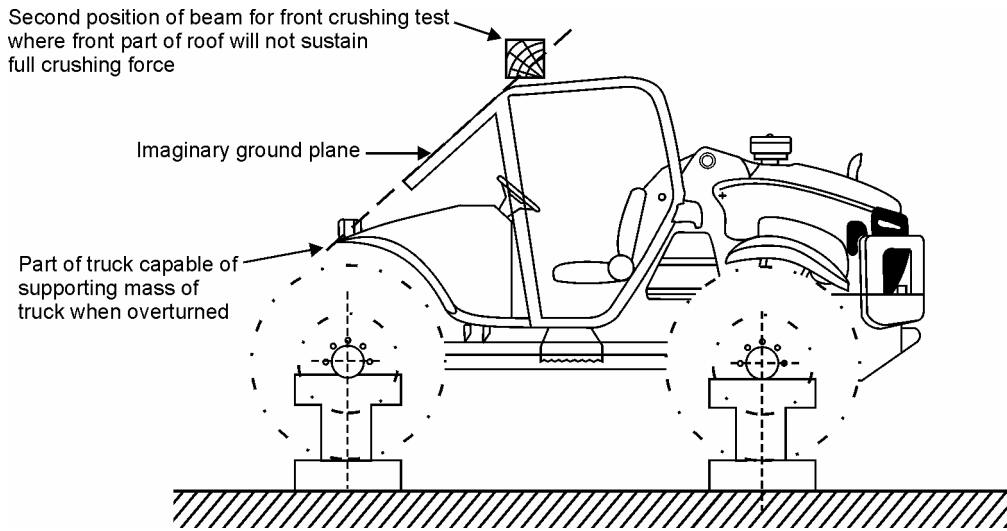

Figure 5.13
Protective cab

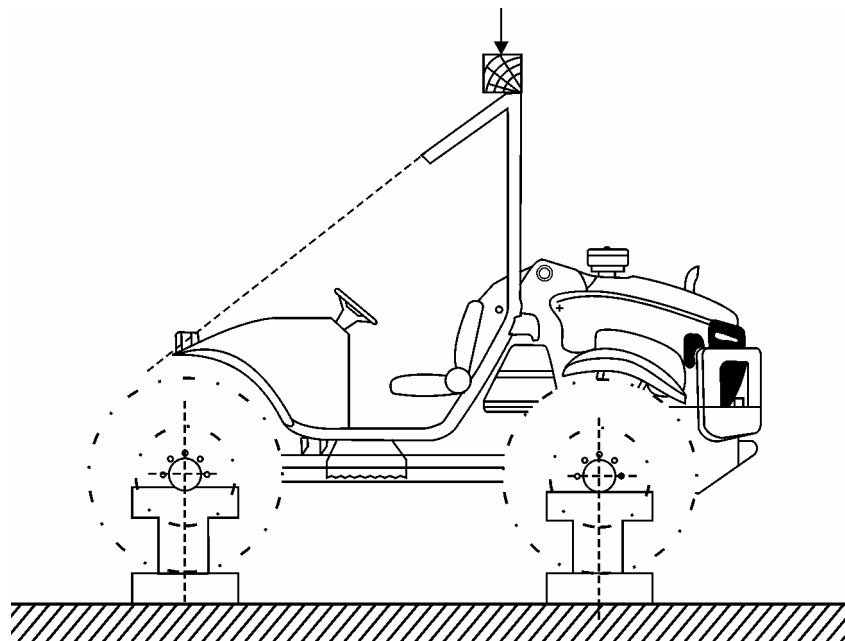

Figure 5.14
Rear roll bar frame

Position of beam for front crushing test when full crushing force not sustained in front

Dimensions	mm	Remarks
A ₁ A ₀	100	minimum
B ₁ B ₀	100	minimum
F ₁ F ₀	250	minimum
F ₂ F ₀	250	minimum
G ₁ G ₀	250	minimum
G ₂ G ₀	250	minimum
H ₁ H ₀	250	minimum
H ₂ H ₀	250	minimum
J ₁ J ₀	250	minimum
J ₂ J ₀	250	minimum
E ₁ E ₀	250	minimum
E ₂ E ₀	250	minimum
D ₀ E ₀	300	minimum
J ₀ E ₀	300	minimum
A ₁ A ₂	500	minimum
B ₁ B ₂	500	minimum
C ₁ C ₂	500	minimum
D ₁ D ₂	500	minimum
I ₁ I ₂	500	minimum
F ₀ G ₀	-	depending on the truck
I ₀ G ₀	-	
C ₀ D ₀	-	
E ₀ F ₀	-	

Table 5.2

Dimensions of the clearance zone

Dimensions in mm

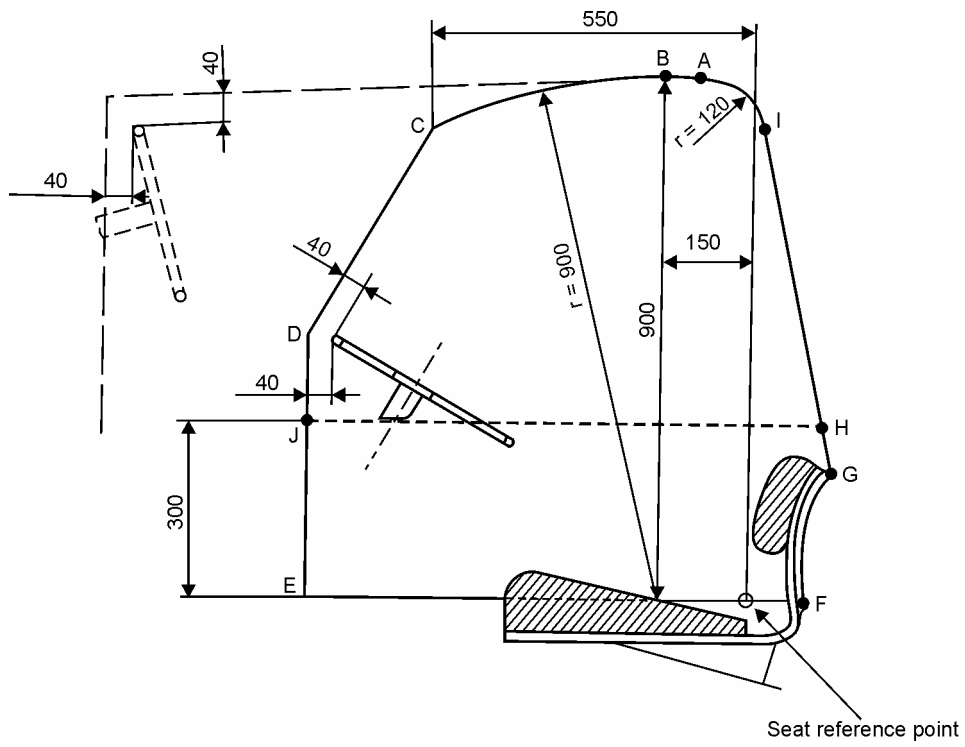

Figure 5.16
Clearance zone side view

Dimensions in mm

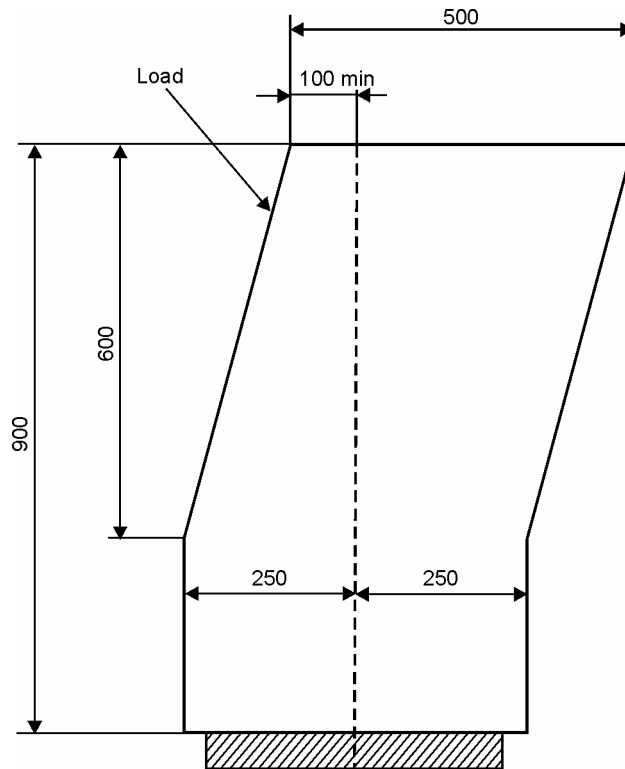

Figure 5.17

Clearance zone rear / front view 150 mm from the seat reference point

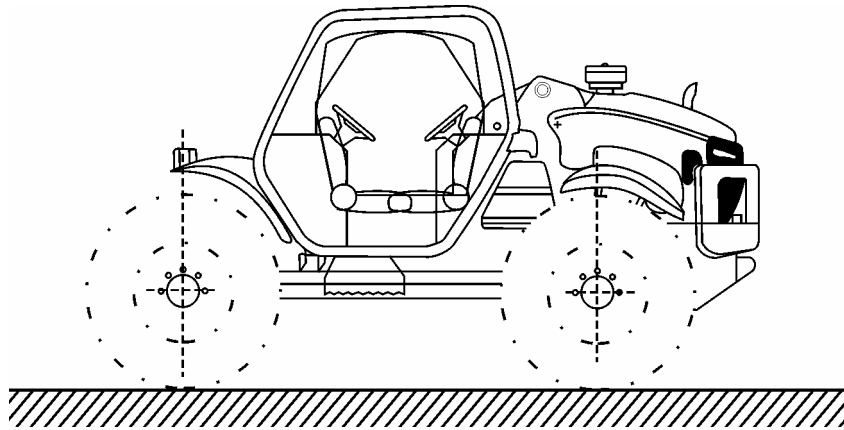

Figure 5.18
Protective cab

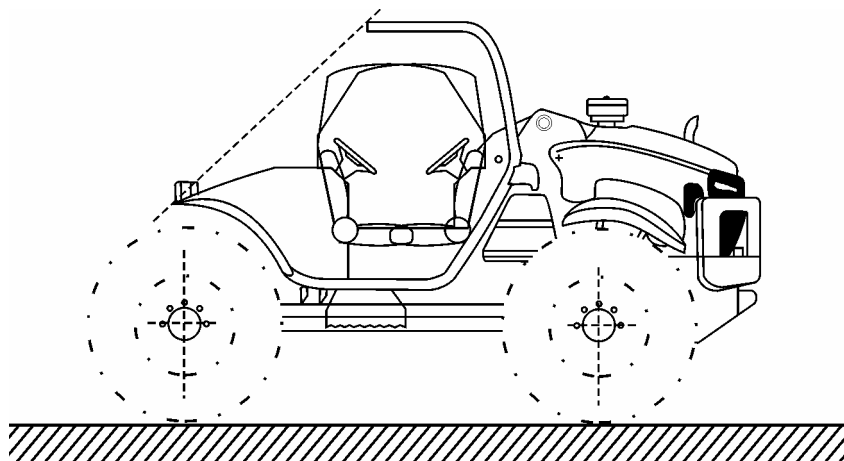
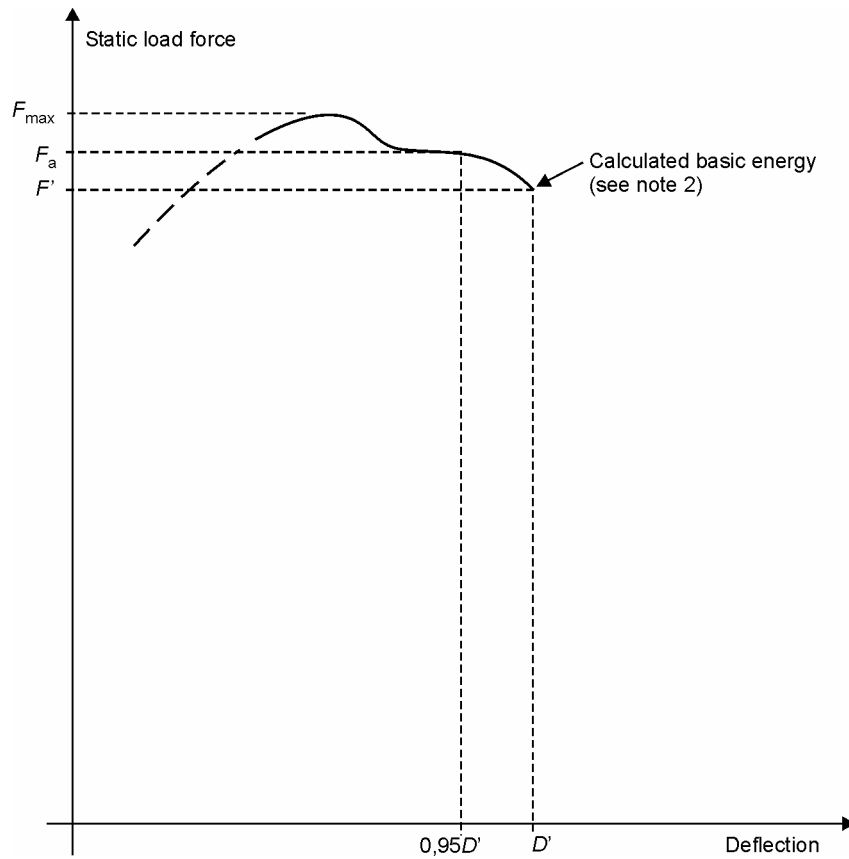

Figure 5.19
Rear roll bar frame

Clearance zone for truck with reversible seat and steering wheel, protective cab and rear roll bar frame



Notes:

1. Locate F_a in relation to $0.95 D'$
2. Overload test not necessary as $F_a < 1.03 F'$

Figure 5.20

Force / deflection curve

Overload test not necessary

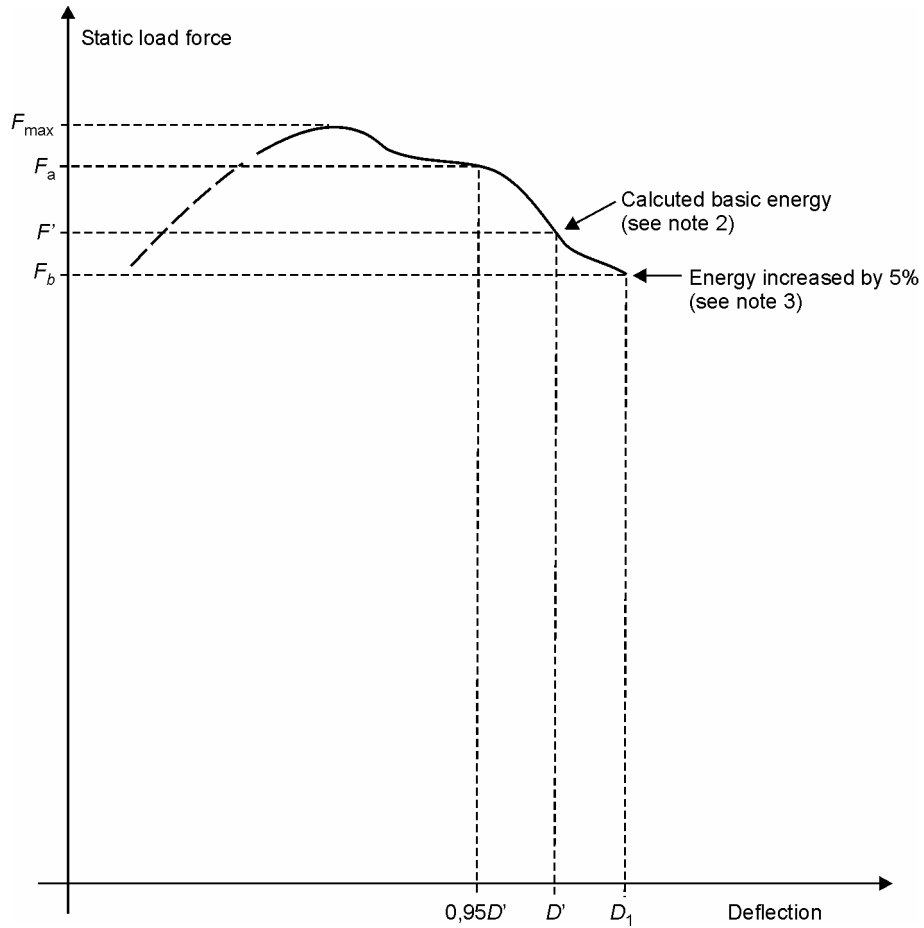

Notes:

1. Locate F_a in relation to $0,95 D'$
2. Overload test necessary as $F_a > 1.03 F'$
3. Overload test performance satisfactory as $F_b > 0.97F'$ and $F_b > 0.8F_{max}$.

Figure 5.21

Force / deflection curve

Overload test necessary

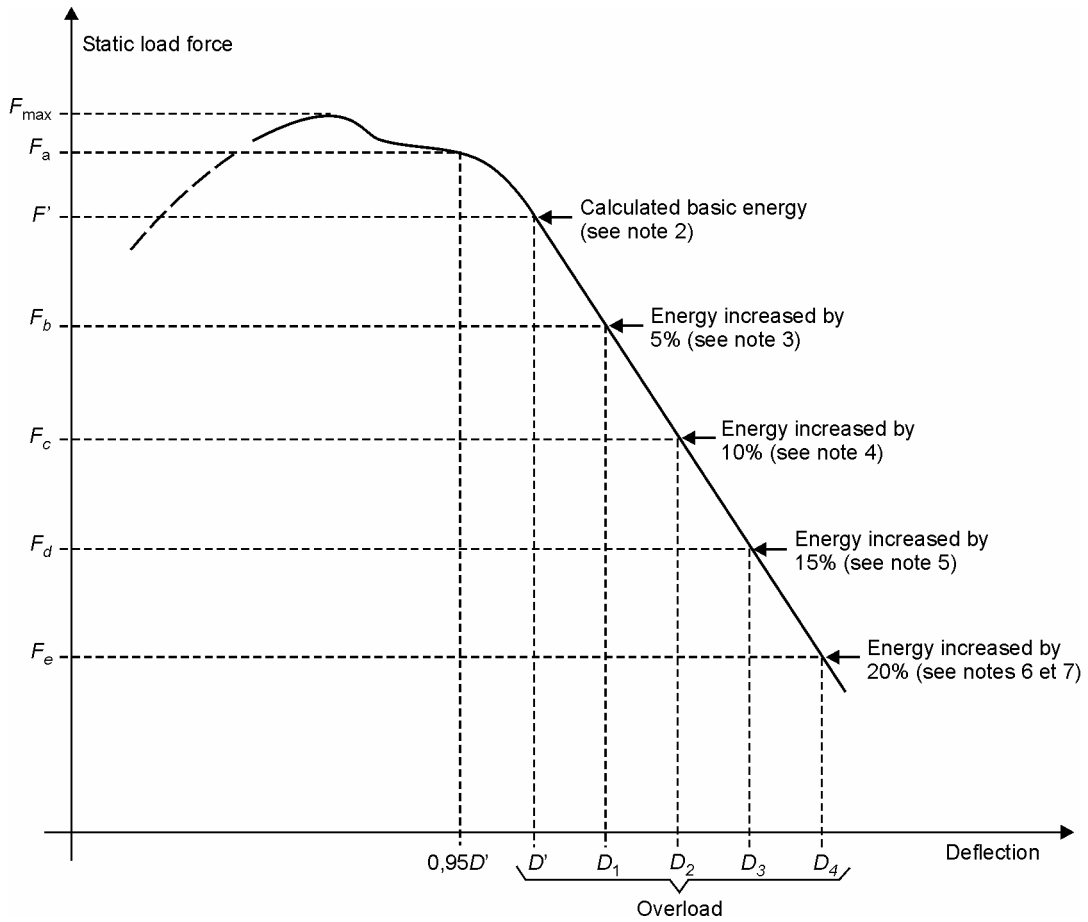

Notes:

1. Locate F_a in relation to $0,95 D'$
2. Overload test necessary as $F_a > 1.03 F'$
3. $F_b < 0.97 F'$ therefore further overload necessary
4. $F_c < 0.97 F_b$ therefore further overload necessary
5. $F_d < 0.97 F_c$ therefore further overload necessary
6. Overload test performance satisfactory, if $F_e > 0.8 F_{max}$
7. Failure at any stage when load drops below $0.8 F_{max}$.

Figure 5.22

Force / deflection curve

Overload test to be continued

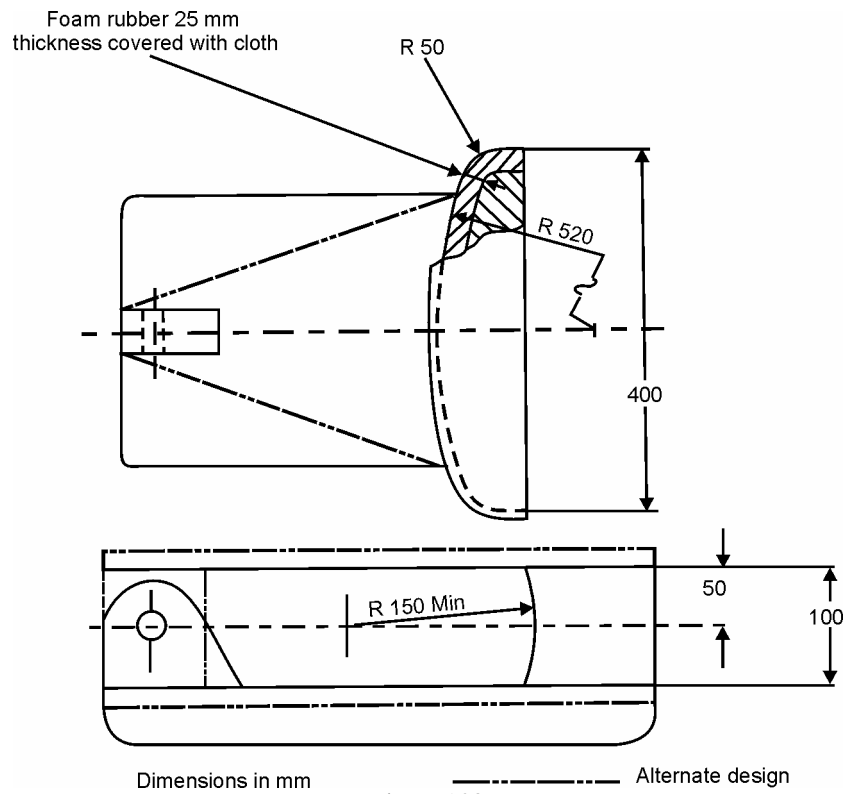

Figure 5.23

The load application device

(The dimensions not shown are optional to satisfy the test facility and do not influence the test results)

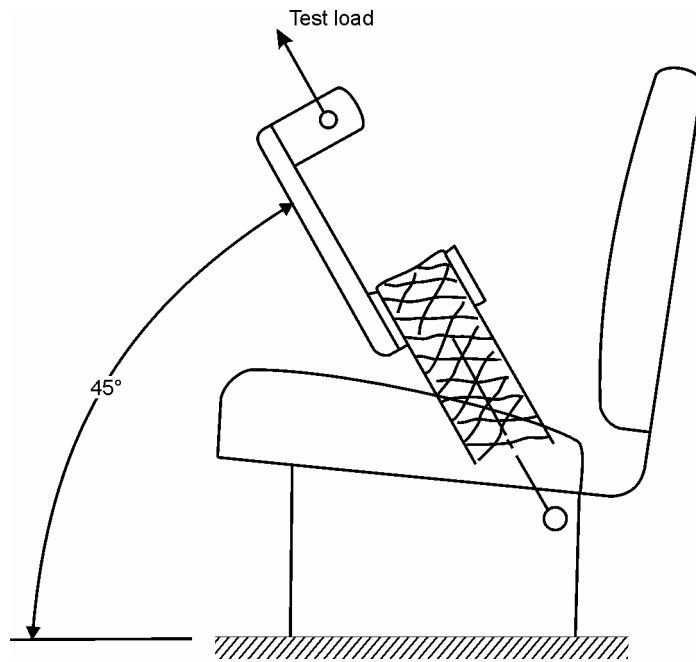

Figure 5.24

Load application in the upward and forward direction

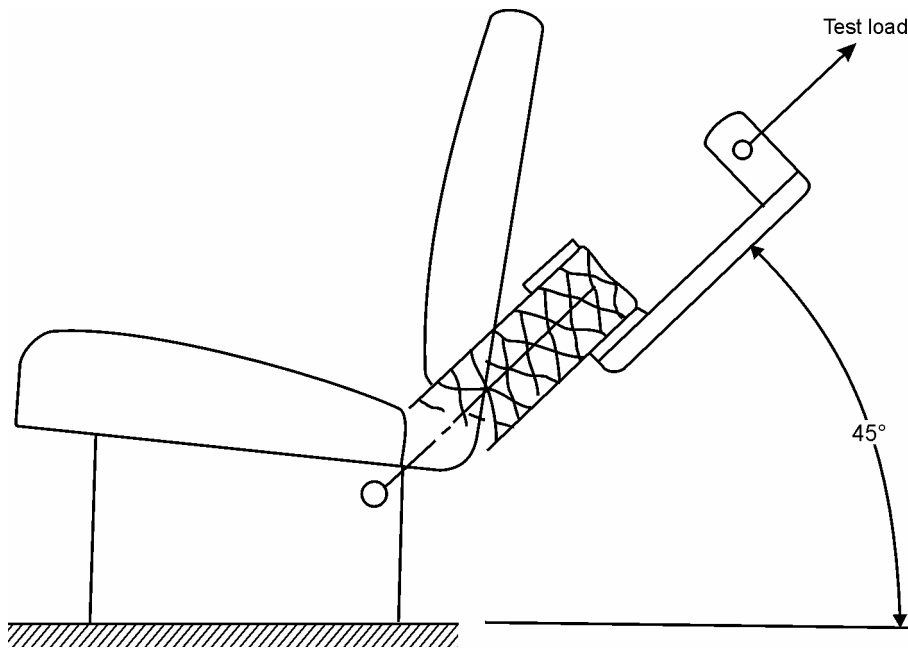

Figure 5.25

Load application in the upward and rearward direction

SPECIMEN TEST REPORT

Note: Units shown below, which appear in ISO 1000:1992; Amd1:1998, shall be stated and followed by national units in parentheses, if necessary.

- Protective structure manufacturer's name and address:
- Submitted for test by:

- Make of the protective structure:
- Model of the protective structure:
- Type of the protective structure: Cab, Frame, Rear rollbar, Cab with integrated frame, etc.

- Date and location of falling-object (FOPS) test:
- Date and location of roll-over (ROPS) test:

1. SPECIFICATION OF TEST TRUCK

1.1 Identification of truck to which the protective structure is fitted for the test

- 1.1.1 - Make of the truck: (*)
 - Model (trade name):
 - Type: 2 WD or 4 WD;
articulated 4 WD or articulated 4 WD with twin (dual) wheels (if applicable)

(*) possibly different from truck manufacturer's name

- 1.1.2 Numbers
 - 1st Serial No. or prototype:
 - Serial No.:

- 1.1.3 Other specifications (if applicable)
 - Model denomination(s) for other countries:
 - Transmission type or gears x ranges:
 - Speed version: 30 or 40 km/h:
 - Manufacturer identification or Technical type number:

1.2 Mass of unballasted truck with protective structure fitted and without driver

Front	kg
Rear	kg
Total	kg

- Mass used for calculating impact energies and crushing forces: kg

1.3 Minimum track and tyre sizes

	Minimum track	Tyre sizes
Front	mm	
Rear	mm	

1.4 Truck seat

- Truck with a reversible driver's position (reversible seat and steering wheel): Yes / No
- Make/ type/ model of seat:
- Make/ type/ model of optional seat(s) and position(s) of the seat reference point (SRP):

(description of seat 1 and SRP position)

(description of seat 2 and SRP position)

(description of seat... and SRP position)

- Seat belt anchorage: Type
- Seat mounting on the tractor: Type
- Other seat components: Type
- Seat operating position in the test: Description

Masses used for calculating the loads

Seat	Make/Model/Type
Components	Mass (Kg)
Driver seat:	
Seat belt assembly:	
Other seat components:	
Total:	

2. SPECIFICATION OF PROTECTIVE STRUCTURE

2.1 **Photographs from side and rear** showing mounting details including mudguards

2.2 **General arrangement drawing of the side and the rear** of the structure including position of the seat reference points (SRP) and details of mountings

2.3 **Brief description** of the protective structure comprising:

- type of construction;
- details of mountings;
- details of cladding and padding;
- means of access and escape;
- additional frame: Yes / No

2.4 **Tiltable or not tiltable/ Folding or not folding structure**

- Tiltable / not tiltable (*)

If it is necessary to tilt with any tools, this should be stated as follows:

- Tiltable with tools/ tiltable without tools (*)

- Folding/ not folding (*)

If it is necessary to fold with any tools, this should be stated as follows:

- Folding with tools/ folding without tools (*)

(*) *delete as appropriate*

2.5 **Dimensions**

Dimensions should be measured with seat pan and backrest loaded and adjusted according to Definition 1.4 of the Code.

When the truck is fitted with different optional seats or has a reversible driver's position (reversible seat and steering wheel), the dimensions in relation to the seat reference points shall be measured in each case (SRP 1, SRP 2, etc.).

- | | | |
|-------|--|----|
| 2.5.1 | Height of roof members above the seat reference point: | mm |
| 2.5.2 | Height of roof members above the truck footplate: | mm |
| 2.5.3 | Interior width of the protective structure 900 mm above the seat reference point: | mm |
| 2.5.4 | Interior width of the protective structure vertically above the seat reference point at the level of centre of the steering wheel: | mm |
| 2.5.5 | Distance from the centre of the steering wheel to the right-hand side of the protective structure: | mm |

2.5.6	Distance from the centre of the steering wheel to the left-hand side of the protective structure:	mm
2.5.7	Minimum distance from the steering wheel rim to the protective structure:	mm
2.5.8	Width of the doorways	
	<ul style="list-style-type: none"> • at the top: • in the middle: • at the bottom: 	<ul style="list-style-type: none"> mm mm mm
2.5.9	Height of the doorways	
	<ul style="list-style-type: none"> • above foot platforms: • above highest mounting steps: • above lowest mounting steps: 	<ul style="list-style-type: none"> mm mm mm
2.5.10	Overall height of the truck with the protective structure fitted:	mm
2.5.11	Overall width of the protective structure (if mudguards are included, this is to be stated):	mm
2.5.12	Horizontal distance from the seat reference point to the rear of the protective structure at a height of 900 mm above the seat reference point:	mm

2.6 Details of materials used in the construction of the protective structure and specifications of steels used

Steel specifications shall be in conformity with ISO 630:1995.

2.6.1	Main frame:	(parts - material - sizes)
	<ul style="list-style-type: none"> • Is steel rimmed, semi-killed, killed?: • steel standard and reference: 	
2.6.2	Mountings:	(parts - material - sizes)
	<ul style="list-style-type: none"> • Is steel rimmed, semi-killed, killed?: • steel standard and reference: 	
2.6.3	Assembly and mounting bolts:	(parts - sizes)
2.6.4	Roof:	(parts - material - sizes)
2.6.5	Cladding:	(parts - material - sizes)
2.6.6	Glass:	(type - grade - sizes)

2.7. Details of truck manufacturer's reinforcements on original parts

3. TEST RESULTS

3.1 Falling-object test

3.1.1 Test conditions

3.1.1.1 Energy level used: J

3.1.1.2 Falling object used

3.1.1.2.1 Standard

- Diameter: mm
- Length: mm
- Mass: kg

3.1.1.2.2 Sphere

- Diameter: mm
- Mass: kg

3.1.1.2.3 Height of drop: mm

3.1.1.2.4 Number of drops:

3.1.1.2.5 Diagram showing location of drop(s):

3.1.2 Photographs

3.1.2.1 Photograph of the falling object and test device before falling-object test(s) have been carried out.

3.1.2.2 Photographs illustrating the upper part and the base of the protective structure after the falling-object test(s) have been carried out.

3.1.3 Results:

3.2 Static loading and crushing tests

3.2.1 Test conditions

- Impact tests were made:
 - to the rear left / right
 - to the front right / left
 - to the side right / left
- Mass used for calculating impact energies and crushing forces: kg
- Energies and forces applied:
 - rear: kJ
 - front: kJ
 - side: kJ
 - crushing force: kN

3.2.2 Permanent deflections measured after the tests

3.2.2.1 Permanent deflections of the extremities of the protective structure measured after the series of tests:

- Back (forwards / backwards):
 - left-hand: mm
 - right-hand: mm
- Front (forwards / backwards):
 - left-hand: mm
 - right-hand: mm
- Sideways (to the left / to the right):
 - front: mm
 - rear: mm
- Top (downwards / upwards):
 - rear: left-hand: mm
 - right-hand: mm
 - front: left-hand: mm
 - right-hand: mm

3.2.2.2 Difference between total instantaneous deflection and residual deflection during sideways impact test (elastic deflection): mm

3.2.2.3 Results:

3.2.3 Curves

A copy of the force/deflection curves derived during the tests shall be included.

If a horizontal overload test was required, the reason for the overload shall be described and the copy of additional force/deflection curves obtained during overload shall be included.

Statement:

The acceptance conditions of these tests relative to the protection of the Deflection-Limiting Volume and of the zone of clearance are fulfilled for the falling-object test and the roll-over test. The structure is a protective structure in accordance with the Code.

3.3 Cold weather performance (resistance to brittle fracture)

Method used to identify resistance to brittle fracture at reduced temperature:

- .
- .
- .

Steel specifications shall be in conformity with ISO 630:1995.

Steel specification: (reference and relevant standard)

3.4 Seat belt anchorage performance

3.4.1 Loading in the forward and upward direction

Driver seat	Make/Model/Type	
GRAVITY FORCE ($F_g = \text{seat mass} \times 9,81$) N	REQUIRED FORCE ($4450N + 4F_g$) N	APPLIED FORCE N

3.4.2. Loading in the rearward and upward direction

Driver seat	Make/Model/Type	
GRAVITY FORCE ($F_g = \text{seat mass} \times 9,81$) N	REQUIRED FORCE ($2225 + 2F_g$) N	APPLIED FORCE N

3.4.3 Curves, drawings and photos

A copy of the force/deflection curves derived during the tests shall be included.

Drawings and/or photos of the seat mounting and seat belt anchorages have to be added.

Statement:

During the test, no structural failure or release of seat, seat adjuster mechanism or other locking service occurred. The seat and safety belt anchorage tested fulfil the requirement of the OECD procedure.

3.5 Truck(s) to which the protective structure is fitted

OECD Approval Number:										
Make	Model	Type	Other specifications	Mass			Tiltable	Wheelbase	Minimum track	
				Front	Rear	Total			Front	Rear
		<i>2/4 WD, etc</i>	<i>where applicable</i>	kg	kg	kg	Yes/ No	mm	mm	

4. MINOR MODIFICATION CERTIFICATE

- OECD approval number according to Code 6:
- Station test n° for the original report:
- Date and location of test:
- Date of approval:
- Modification number: MOD
- The previous Modification Certificate (MOD.____.) remains/does not remain valid.

4.1 Specification of the Protective Structure

- Frame or Cab:
- Manufacturer:
- Submitted for test by:
- Make:
- Model:
- Type:
- Serial Number from which modification applies:

4.2 Truck(s) to which the Protective Structure is fitted

OECD Approval Number :										
Make	Model	Type	Other specifications	Mass			Tiltable	Wheel-Base	Minimum track	
				Front	Rear	Total			Front	Rear
		<i>2/4 WD, etc</i>	<i>where applicable</i>	kg	kg	kg	Yes/ No	mm	mm	

4.3 Details of Modifications

Since the original test report the following modifications have been made:

4.4 Statement

The effect of these modifications on the strength of the protective structure has been examined.

The modifications are considered not to affect the results of the original test.

The original test report therefore applies to the protective structure of the modified truck.

Drafted on the responsibility of the national Designated Authority by the Station which carried out the original test, this certificate is circulated as an annex to the original test report and subject to the same circulation.

Signature:

Date:

Location: