

**CODE 10**

**OECD STANDARD CODE FOR THE OFFICIAL TESTING OF  
FALLING OBJECT PROTECTIVE STRUCTURES ON AGRICULTURAL  
AND FORESTRY TRACTORS**

## TABLE OF CONTENTS

	<u>page</u>
<b>INTRODUCTION</b>	3
<b>1. DEFINITIONS</b>	3
1.1 Agricultural and forestry tractor	3
1.2 Falling Object Protective Structure (FOPS)	3
1.3 Safety zone	3
1.3.1 Clearance zone	3
1.3.2 Deflection-Limiting Volume (DLV)	3
1.3.3 Top area of the safety zone	4
1.4 Permissible measurement tolerances	4
<b>2. FIELD OF APPLICATION</b>	4
2.1 Purpose	4
<b>3. RULES AND DIRECTIONS</b>	4
3.1 General regulations	4
3.2 Apparatus and procedure	5
3.3 Performance requirements	7
3.4 Extension to other tractor models	7
3.5 Minor modifications	7
3.6 Labelling	8
3.7 Cold weather performance of protective structures	8
<b>SPECIMEN TEST REPORT</b>	12
1. SPECIFICATION OF TEST TRACTOR	12
2. SPECIFICATION OF PROTECTIVE STRUCTURE	12
3. TEST RESULTS	13
4. MINOR MODIFICATION CERTIFICATE	15

**CODE 10**

**OECD STANDARD CODE FOR  
THE OFFICIAL TESTING OF FALLING OBJECT PROTECTIVE STRUCTURES ON  
AGRICULTURAL AND FORESTRY TRACTORS**

**INTRODUCTION**

The FOPS testing procedure considered in this Code refers to the tractor used in its traditional agricultural tasks. However, it is reasonable to consider that a specific use of the tractor, such as dedicated forestry applications, for which generally the tractor has to be properly equipped, can need FOPS tests at higher levels of energy. These FOPS tests can be carried out using other appropriate test methods.

**1. DEFINITIONS**

**1.1 *Agricultural and forestry tractors***

Self-propelled wheeled vehicles, having at least two axles, or with tracks, designed to carry out the following operations, primarily for agricultural and forestry purposes:

- to pull trailers;
- to carry, pull or propel agricultural and forestry tools or machinery and, where necessary, supply power to operate them with the tractor in motion or stationary.

**1.2 *Falling Object Protective Structure (FOPS)***

System of structural members arranged in such a way as to provide operators with reasonable protection from falling objects.

**1.3 *Safety zone***

**1.3.1 Clearance zone**

For tractors equipped with ROPS tested in accordance with Codes 3, 4, 6 and 7 the safety zone shall comply with the specifications of the Clearance Zone as described in point 1.5 of each of these codes.

**1.3.2 Deflection-Limiting Volume (DLV)**

For tractors equipped with ROPS tested in accordance with Code 8 the safety zone shall comply with the Deflection-Limiting Volume (DLV), as described in ISO 3164:1995.

In the event the tractor has a reversible driver's position (reversible seat and steering wheel), the safety zone shall be the envelope of the two DLVs defined by the two different positions of the steering wheel and the seat.

### 1.3.3 Top area of the safety zone

Respectively the top plane of the DLV or the surface defined by points I<sub>1</sub>, A<sub>1</sub>, B<sub>1</sub>, C<sub>1</sub>, C<sub>2</sub>, B<sub>2</sub>, A<sub>2</sub>, I<sub>2</sub> of clearance zone for Codes 3 and 4; the plane described in 1.5.2.3 and 1.5.2.4 of Code 6; and the surface defined by points H<sub>1</sub>, A<sub>1</sub>, B<sub>1</sub>, C<sub>1</sub>, C<sub>2</sub>, B<sub>2</sub>, A<sub>2</sub>, H<sub>2</sub> for Code 7 .

### 1.4 Permissible measurement tolerances

Distance	± 5 % of maximum deflection measured, or ± 1 mm
Mass	± 0.5 %

## 2. FIELD OF APPLICATION

This OECD Standard Code is applicable to agricultural and forestry tractors having at least two axles for pneumatic tyred wheels or having tracks instead of wheels.

### 2.1 Purpose

This Code establishes test procedures and performance requirements for those tractors exposed to potential hazards of falling objects encountered carrying out some agricultural tasks during their normal operation.

## 3. RULES AND DIRECTIONS

### 3.1 General regulations

3.1.1 The protective structure may be manufactured either by the tractor manufacturer or by an independent firm. In either case the test is only valid for the model of tractor on which the test is carried out. The protective structure must be retested for each model of tractor to which it is to be fitted. However, testing stations may certify that the strength tests are also valid for tractor models derived from the original model by modifications to the engine, transmission and steering and front suspension (*see below 3.4: Extension to other tractor models*). On the other hand, more than one protective structure may be tested for any one model of tractor.

3.1.2 The protective structure submitted for test shall be supplied attached in the normal manner to the tractor or tractor chassis on which it is used. The tractor chassis shall be complete including attaching brackets and other parts of the tractor that may be affected by loads imposed by the protective structure.

3.1.3 A protective structure may be designed solely to protect the driver in the event of an object falling. Onto this structure it may be possible to fit weather protection for the driver, of a more or less temporary nature. The driver will usually remove this in warm weather. There are protective structures, however, in which the cladding is permanent and warm weather ventilation provided by windows or flaps. As the cladding may add to the strength of the structure and if removable may well be absent when an accident occurs, all parts that can be so taken away by the driver shall be removed for the purpose of the test. Doors, roof hatch and windows that can be opened shall be either removed or fixed in the open position for the test, so that they do not add to the strength of the protective structure. It shall be noted whether, in this position, they would create a hazard for the driver in the event of an object falling. Throughout the remainder of these rules, reference will only be made to testing the protective structure. It must be understood that this includes cladding not of a temporary nature.

A description of any temporary cladding supplied is to be included in the specifications. All glass or similar brittle material shall be removed prior to the test. Tractor and protective structure components which might sustain needless damage during the test and which do not affect the strength of the protective structure or its dimensions may be removed prior to the test if the manufacturer wishes. No repairs or adjustment may be carried out during the test.

3.1.4 Should the same structure be used for FOPS and ROPS evaluations the FOPS test shall precede the ROPS tests (according to Codes 3, 4, 6, 7 or 8), the removal of impact dents or replacement of the FOPS cover is permitted.

### 3.2 Apparatus and procedures

#### 3.2.1 Apparatus

##### 3.2.1.1 Drop test object

The drop test object shall be a spherical object dropped from a height sufficient to develop the energy of 1365 J.

ENERGY LEVEL (J)	SAFETY ZONE	DROP OBJECT	DIMENSIONS (mm)	MASS (kg)
1365	Clearance zone*	Sphere	$200 \leq \text{Diameter} \leq 250$	$45 \pm 2$
1365	DLV**	Sphere	$200 \leq \text{Diameter} \leq 250$	$45 \pm 2$

\* For tractors the ROPS of which is to be tested according to Codes 3, 4, 6 or 7.

\*\* For tractors the ROPS of which is to be tested according to Code 8.

The test object, whose impact surface has properties to protect against deformation during testing, shall be a solid steel or ductile iron sphere with a typical mass of  $45 \pm 2$  kg and a diameter between 200 and 250 mm.

The drop height of the test object is defined as a function of its mass.

3.2.1.2 Means of raising the drop test object to the required height.

3.2.1.3 Means of releasing the drop test object so that it drops without restraint.

3.2.1.4 Surface of such firmness that it is not penetrated by the machine or test bed under the loading of the drop test.

3.2.1.5 Means of determining whether the FOPS enters the safety zone during the drop test. This may be either of the following:

- a safety zone template, placed upright, made of a material which will indicate any penetration by the FOPS; grease or other suitable material may be put on the lower surface of the FOPS cover to indicate such penetration;
- a dynamic instrumentation system of sufficient frequency response to indicate the expected deflection of the FOPS with respect to the safety zone.

### 3.2.1.6 Safety zone requirements:

The safety zone template, if any, shall be fixed firmly to the same part of the tractor as the operator's seat and shall remain there during the entire formal test period.

### 3.2.2 Procedure

The drop test procedure shall consist of the following operations, in the order listed.

3.2.2.1 Place the drop test object (3.2.1.1) on the top of the FOPS, at the location designated in 3.2.2.2.

3.2.2.2 When the safety zone is represented by the clearance zone the point of impact shall be at a point which is furthest removed from major structural members (Figure 1).

When the safety zone is represented by the DLV, the impact location shall be entirely within the vertical projection of the safety zone, in that volume's upright position, on the top of the FOPS. It is intended that the drop location includes at least a portion of the vertical projection of the top plane area of the safety zone.

Two cases have to be considered:

3.2.2.2.1 Case 1: Where major, upper, horizontal members of the FOPS do not enter the vertical projection of the safety zone on the top of the FOPS.

The drop test object shall be placed such that it is as close as possible to the centre of gravity of the upper FOPS structure (Figure 2).

3.2.2.2.2 Case 2: Where major, upper, horizontal members of the FOPS do enter the vertical projection of the safety zone on the top of the FOPS.

When the covering material of all the surface areas above the safety zone is of uniform thickness, the centre of the drop test object shall be in the surface of greatest area. This area is the vertical projected area of the safety zone without major, upper, horizontal members. The centre of the drop test object shall be at that point, within the surface of greatest area, which has the least possible distance from the centroid of the top of the FOPS (Figure 2).

3.2.2.3 Where different materials or a different thickness are used in different areas above the safety zone, each area in turn shall be subjected to a drop test. If design features, such as openings for windows or equipment, or variations in cover material or thickness, indicate a more vulnerable location within the vertical projection of the safety zone, the drop location should be adjusted to that location. In addition, if openings in the FOPS cover are intended to be filled with devices or equipment to provide adequate protection, those devices or equipment shall be in place during the drop test.

3.2.2.4 Raise the drop test object vertically to a height above the position indicated in 3.2.2.1 and 3.2.2.2 to develop the energy of 1365 J.

3.2.2.5 Release the drop object so that it falls without restraint onto the FOPS.

3.2.2.6 As it is unlikely that the free fall will result in the drop test object hitting at the location as specified in 3.2.2.1 and 3.2.2.2, the following limits are placed on deviations.

3.2.2.7 The impact of the drop test object shall be entirely within a circle of 100 mm radius whose centre shall coincide with the vertical centre line of the drop test object as positioned according to 3.2.2.1 and 3.2.2.2).

3.2.2.8 There is no limitation on location or attitude of subsequent impacts due to rebound.

### **3.3 Performance requirements**

The safety zone shall not be entered into by any part of the protective structure under the first or subsequent impact of the drop test object. Should the drop test object penetrate the FOPS, it shall be considered to have failed that test.

The FOPS shall completely cover and overlap the vertical projection of the safety zone.

If the tractor is to be equipped with a FOPS fitted on an approved ROPS, the testing station which performed the ROPS test will normally be the only one allowed to carry out the FOPS test and to require for the approval.

### **3.4 Extension to other tractor models**

For a protective structure which has fulfilled the acceptance conditions and which is designed to be used on other models of tractors, the impact test need not be carried out on each model of tractor, provided that the protective structure and tractor comply with the conditions referred to in 3.4.1 to 3.4.5 hereunder.

3.4.1 The station which performed the original test will be the only station to be allowed to request an extension of approval if required by the manufacturer.

3.4.2 The method of attachment and the tractor components to which the attachment is made shall be identical or of equivalent strength.

3.4.3 Any components such as mudguards and bonnet that may provide support for the protective structure shall be identical or judged to give at least the same support.

3.4.4 The position and critical dimensions of the seat in the protective structure and the relative position of the protective structure on the tractor shall be such that the safety zone would have remained within the protection of the structure throughout the test.

3.4.5 The test report shall contain a reference to the original test report.

### **3.5 Minor modifications**

If there are minor modifications on the tractor such as changes of vehicle colour, decals, make or model denominations for marketing purposes, or on the protective structure like design of non-structural sheet metal parts, the testing station that has carried out the original test can issue a "Minor Modification Certificate" on the national Designated Authority's responsibility, stating all changes and confirming that the results of the drop test is not affected. No test is necessary. This certificate shall be drafted according to the specimen provided for in the Code, as an annex to the original test report and subject to the same circulation requirements.

### **3.6     *Labelling***

3.6.1    OECD labelling is optional. If a label is utilised, it shall contain at least the following information:

3.6.1.1   name and address of the manufacturer of the protective structure;

3.6.1.2   protective structure identification number (design or serial number);

3.6.1.3   tractor make, model(s) or series number(s) that the protective structure is designed to fit;

3.6.1.4   OECD approval number of test report;

3.6.1.5   energy level met in test.

3.6.2    The label shall be durable and permanently attached to the protective structure such that it can be easily read and it shall be protected from environmental damage.

### **3.7     *Cold weather performance of protective structures***

3.7.1    If the protective structure is claimed to have properties resistant to cold weather embrittlement, the manufacturer shall give details that shall be included in the report.

3.7.2    The following requirements and procedures are intended to provide strength and resistance to brittle fracture at reduced temperatures. It is suggested that the following minimum material requirements shall be met in judging the protective structure's suitability at reduced operating temperatures in those countries requiring this additional operating protection:

3.7.2.1   Bolts and nuts used to attach the protective structure to the tractor and used to connect structural parts of the protective structure shall exhibit suitable controlled reduced temperature toughness properties.

3.7.2.2   All welding electrodes used in the fabrication of structural members and mounts shall be compatible with the protective structure material as given in 3.8.2.3 below.

3.7.2.3   Steel materials for structural members of the protective structure shall be of controlled toughness material exhibiting minimum Charpy V-Notch impact requirements as shown in Table 1. Steel grade and quality shall be specified in accordance with ISO 630:1995, Amd 1:2003.

Steel with an as-rolled thickness less than 2.5 mm and with a carbon content less than 0.2 per cent is considered to meet this requirement.

Structural members of the protective structure made from materials other than steel shall have equivalent low impact resistance.

3.7.2.4   When testing the Charpy V-Notch impact energy requirements, the specimen size shall be no less than the largest of the sizes stated in Table 1 that the material will permit.

3.7.2.5   The Charpy V-Notch tests shall be made in accordance with the procedure in ASTM A 370-1979, except for specimen sizes that shall be in accordance with the dimensions given in Table 1.

3.7.2.6   Alternatives to this procedure are the use of killed or semi-killed steel for which an adequate specification shall be provided. Steel grade and quality shall be specified in accordance with ISO 630:1995, Amd 1:2003.

3.7.2.7 Specimens are to be longitudinal and taken from flat stock, tubular or structural sections before forming or welding for use in the protective structure. Specimens from tubular or structural sections are to be taken from the middle of the side of greatest dimension and shall not include welds.

Specimen size mm	Absorbed energy J	
	At –30 °C	At –20 °C <sup>2)</sup>
10 × 10 <sup>1)</sup>	11.0	27.5
10 × 9	10	25
10 × 8	9.5	24
10 × 7.5 <sup>1)</sup>	9.5	24
10 × 7	9	22.5
10 × 6.7	8.5	21
10 × 6	8	20
10 × 5 <sup>1)</sup>	7.5	19
10 × 4	7	17.5
10 × 3.3	6	15
10 × 3	6	15
10 × 2.5 <sup>1)</sup>	5.5	14
1) Indicates preferred size. Specimen size shall be no less than largest preferred size that the material permits.		
2) The energy requirement at –20 °C is 2.5 times the value specified for –30 °C. Other factors affect impact energy strength, i.e. direction of rolling, yield strength, grain orientation and welding. These factors shall be considered when selecting and using steel.		

Minimum Charpy V-Notch impact energy requirements for protective structure material at specimen temperatures of -20°C and -30°C

Table 10.1

**Impact Energy**

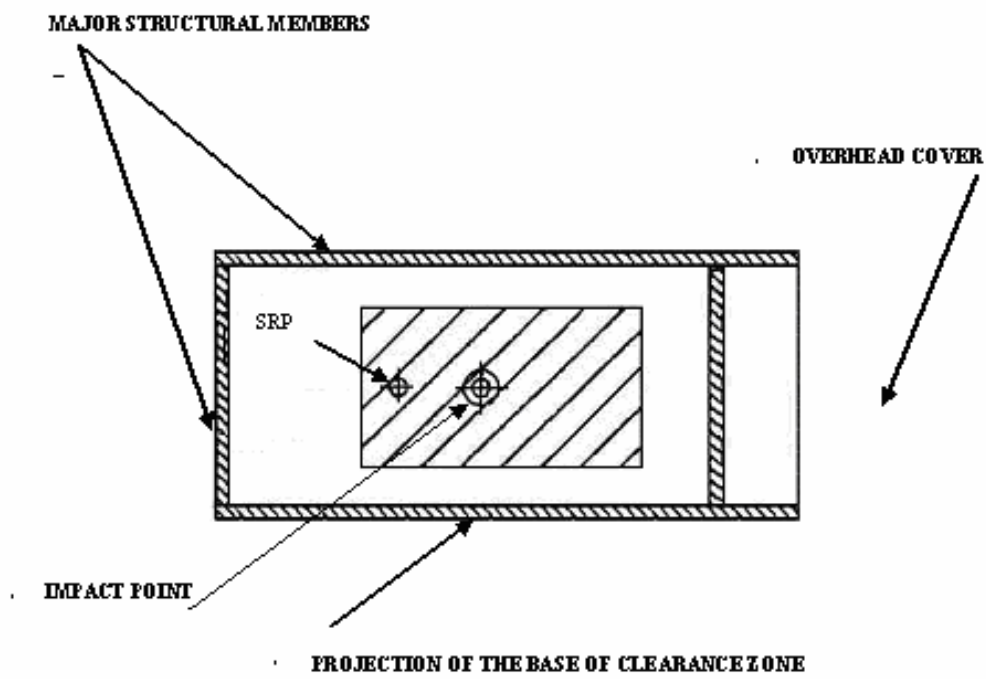
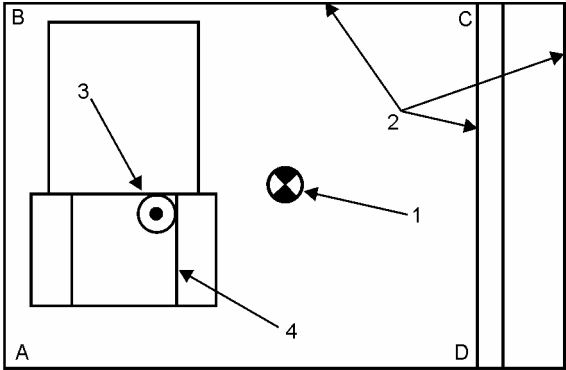
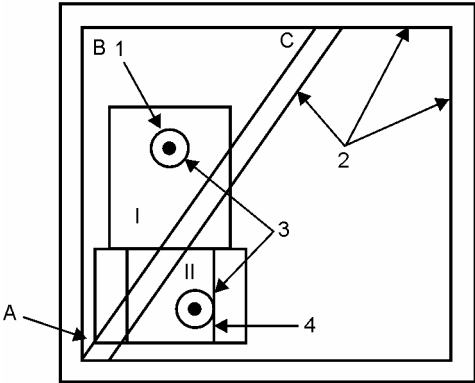

Figure 10.1  
Impact point referred to the clearance zone



Case 1

- Key
- 1. Centroid of A-B-C-D
  - 2. Major members
  - 3. Drop object
  - 4. DLV top plane



Case 2

- Key
- 1. Centroid of A-B-C
  - 2. Major members
  - 3. Drop object
  - 4. DLV top plane
- Note: I has a greater area than II

Figure 10.2

**Drop test impact points**

## SPECIMEN TEST REPORT

**Note:** Units shown below, which appear in ISO 1000:1992; Amd1:1998, shall be stated and followed by national units in parentheses, if necessary.

- Protective structure manufacturer's name and address:
- Submitted for test by:
- Make of the protective structure:
- Model of the protective structure:
- Type of the protective structure: Cab, Frame, Rear rollbar with roof, Cab with integrated frame, etc.
- Date and location of test:

### 1. SPECIFICATION OF TEST TRACTOR

#### 1.1 Identification of tractor to which the protective structure is fitted for the test

##### 1.1.1 Make of the tractor: (\*)

- Model (trade name):
- Type: 2 WD or 4 WD; rubber or steel tracks (if applicable); articulated 4 WD or articulated 4 WD with twin (dual) wheels (if applicable)
- (\*) it may differ from the tractor manufacturer's name

##### 1.1.2 Numbers

- 1<sup>st</sup> Serial No. or prototype:
- Serial No.:

##### 1.1.3 Other specifications (if applicable)

- Model denomination(s) for other countries:
- Transmission type or gears x ranges:
- Speed version:
- Manufacturer identification or Technical type number:

#### 1.2 Tractor seat

- Tractor with a reversible driver's position (reversible seat and steering wheel): Yes / No
- Make / type / model of seat:
- Make / type / model of optional seat(s) and position(s) of the seat reference point (SRP) or seat index point (SIP):
  - (description of seat 1 and SRP or SIP position)
  - (description of seat 2 and SRP or SIP position)
  - (description of seat ... and SRP or SIP position)

### 2. SPECIFICATION OF PROTECTIVE STRUCTURE

#### 2.1 Photographs showing mounting details.

**2.2 General arrangement drawing** of the structure including position of the seat reference points (SRP or SIP) and details of mountings.

**2.3 Brief description** of the protective structure comprising:

- 2.3.1 type of construction:
- 2.3.2 details of mountings:

**2.4 Dimensions**

When the tractor is fitted with different optional seats or has a reversible driver’s position (reversible seat and steering wheel), the dimensions in relation to the seat reference points or the seat index points shall be measured in each case (SRP 1, SRP 2, etc. or SIP 1, SIP 2, etc.).

- 2.4.1 Height of roof members above the seat reference point or seat index point: mm
- 2.4.2 Height of roof members above the tractor footplate: mm
- 2.4.3 Overall height of the tractor with the protective structure fitted: mm
- 2.4.4 Overall width of the protective structure (if mudguards are included, this is to be stated): mm

**2.5 Details of materials used in the construction of the protective structure and specifications of steels used**

Steel specifications shall be in accordance with ISO 630:1995, Amd 1: 2003.

- 2.5.1 Main frame: (parts – material – sizes)
  - Is steel rimmed, semi-killed or killed:
  - Steel standard and reference:
- 2.5.2 Mountings: (parts – material – sizes)
  - Is steel rimmed, semi-killed or killed:
  - Steel standard and reference:
- 2.5.3 Assembly and mounting bolts: (parts – sizes)
- 2.5.4 Roof: (parts – material – sizes)

**2.6 Details of tractor manufacturer’s reinforcements on original parts**

**2.7 OECD ROPS test report approval number according to Code \_\_\_\_**

**3. TEST RESULTS**

**3.1 Falling-object test**

3.1.1 Test conditions:

3.1.1.1 Falling object used:

- 3.1.1.1.1 Sphere:
  - Diameter: (mm)
  - Mass: (kg)
- 3.1.1.1.2 Height of drop: (mm)
- 3.1.1.1.3 Number of drops:
- 3.1.1.1.4 Energy level met in test: (J)

3.1.2 Results:

**Statement:**

**The acceptance conditions of the test are fulfilled. The structure is a Falling Object Protective Structure in accordance with the Code.**

3.1.3 Documentation of impact location(s) showing the location relative to the safety zone.

3.1.4 Photographs:

One photograph of the test object and test arrangement before application of test. Additional photograph as necessary to show top and bottom of FOPS structure after the test.

**3.2 Cold weather performance (resistance to brittle fracture)**

Method used to identify resistance to brittle fracture at reduced temperature:

- 
- 
- 

Steel specifications shall be in conformity with ISO 630:1995, Amd 1: 2003.

Steel specification: (reference and relevant standard)

**3.3 Tractor(s) to which the protective structure is fitted**

OECD Approval Number:										
Make	Model	Type	Other specifications	Mass			Tiltable	Wheel-Base	Minimum track	
				Front	Rear	Total			Front	Rear
		2/4 WD, etc	where applicable	kg	kg	kg	Yes / No	mm	mm	

**4. MINOR MODIFICATION CERTIFICATE**

- OECD approval number according to Code \_\_\_\_
- Station test n° for the original report:
- Date and location of test:
- Date of approval:
- Modification number: MOD
- The previous Modification Certificate (MOD ....) remains / does not remain valid.

**4.1 Specification of the Protective Structure:**

- Frame or Cab:
- Manufacturer:
- Submitted for test by:
- Make:
- Model:
- Type:
- Serial Number from which modification applies:

**4.2 Denomination of Tractor(s) to which the Protective Structure is fitted**

OECD Approval Number:										
Make	Model	Type	Other specifications	Mass			Tiltable	Wheel-Base	Minimum track	
				Front	Rear	Total			Front	Rear
		2/4 WD, etc	where applicable	kg	kg	kg	Yes / No	mm	mm	

**4.3 Details of modifications**

Since the original test report the following modifications have been made:  
 .....  
 .....

**4.4 Statement**

The effect of these modifications on the strength of the protective structure has been examined.

The modifications are considered not to affect the results of the original test.

The original test report therefore applies to the protective structure of the modified tractor.

Drafted on the responsibility of the national Designated Authority by the Station which carried out the original test, this certificate is circulated as an annex to the original test report and subject to the same circulation.

Signature:

Date:

Location: